

Total No. of Questions : 40]

Code No. **40**

Total No. of Printed Pages : 7]

March, 2010
ELECTRONICS

Time : 3 Hours 15 Minutes]

[Max. Marks : 90

- Note :*
- i) The question paper has *four* **Parts A, B, C & D**.
 - ii) Question No. **23** in **Part C** and Question No. **32** in **Part D** are from practicals.
 - iii) Read the instructions given for each Part.

PART – A

Note : Answer *all* questions.

10 × 1 = 10

1. Mention moderately doped region of a Transistor.
2. What is direct coupling ?
3. What happens to the output impedance with negative voltage series feedback amplifier ?
4. Draw the output waveform of Differentiator when sine wave input is applied.
5. What is the value of feedback fraction of Wien-bridge oscillator ?
6. Define signal to noise ratio.
7. In AM modulation the Signal Amplitude is 15 mV and Carrier Amplitude is 30 mV. Find modulation index.
8. Write the Boolean expression for two input of XOR gate.
9. Give an example for non-weighted code.
10. Expand MTSO.

[Turn over

Code No. 40

2

PART – B

Note : Answer any *ten* questions.

10 × 2 = 20

11. Write the *three* operating regions of a transistor. Which region is used in amplifiers ?
12. A transistor has $\beta = 100$, if base current is $50 \mu\text{A}$. Determine the collector current and α .
13. Why do we need multistage amplifier ? Write the expression for overall voltage gain of two-stage amplifier.
14. Distinguish between negative feedback and positive feedback.
15. Draw the circuit diagram of op-amp integrator and write the output voltage expression.
16. State Barkhausen criterion for sustained oscillations.
17. Mention the layers of the ionosphere.
18. Calculate the carrier swing of FM wave for the frequency deviation 5 kHz.
19. Draw the circuit diagram of linear diode detector.
20. Write the logic symbol and Boolean expression for two input NAND gate.
21. Convert $21_{(10)}$ into Excess-3 Code.
22. What is satellite ? Mention *one* application of it.

PART – C

I. Answer the following question :

1 × 4 = 4

23. Using the following data, calculate the theoretical and experimental value of frequency of Wien-bridge oscillator :

$$(R_1 = R_2 = R ; C_1 = C_2 = C)$$

Sl.No.	R in k Ω	C in μF	T in ms	Frequency	
				Theoretical	Experimental
1	1	0.01	0.065		
2	2.2	0.01	0.140		

OR

Using the following data calculate voltage gains of non-inverting operational amplifier and compare the same with theoretical values :

Input voltage = 2 volts.

Trial No.	Resistance in kΩ		O/P Voltage in Volts	Voltage Gain	
	R_i	R_f		Practical	
1	10	10 k	3.9		
2	10	20 k	5.8		

II. Answer any *five* questions :

5 × 4 = 20

24. Explain the working of NPN transistor with neat diagram.

25. A multistage amplifier has the individual voltage gains of 50, 100 and

150. What is the overall gain in dB ? Express each gain in dB.

[Turn over

Code No. 40

4

26. Derive an expression for the output impedance of voltage series negative feedback amplifier.
27. Derive an expression for output voltage of an op-amp inverting amplifier. Also show input and output waveforms.
28. Explain the working of Hartley oscillator with neat circuit diagram.
29. Derive an expression for the instantaneous voltage of the frequency modulated wave.
30. Explain with block diagram and truth table, the action of JK Flip-flop.
31. What is Half Adder ? Realise Half Adder using XOR and basic gate along with output Boolean expression and write its truth table.

PART – D

- I. Answer the following question : 1 × 6 = 6
32. Write the pin diagram of IC 7400. Realise NOT, OR and AND gates experimentally using IC 7400.

OR

Describe an experiment to study the frequency response of CB-amplifier.

II. Answer any *five* questions :

5 × 6 = 30

33. a) Classify the amplifiers based on configuration and write their applications.

b) The emitter current of a transistor is 100 mA with the collector resistor $R_c = 5 \text{ k } \Omega$. Calculate voltage gain. Given $V_e = 26 \text{ mV}/I_E$. 4 + 2

34. a) What is photo-transistor ? Write the symbol and any *two* uses of it.

b) An amplifier has lower cut-off frequency 500 Hz and upper cut-off frequency of 400 kHz. Calculate bandwidth. 4 + 2

35. a) Find the output voltage for the following circuit diagram :

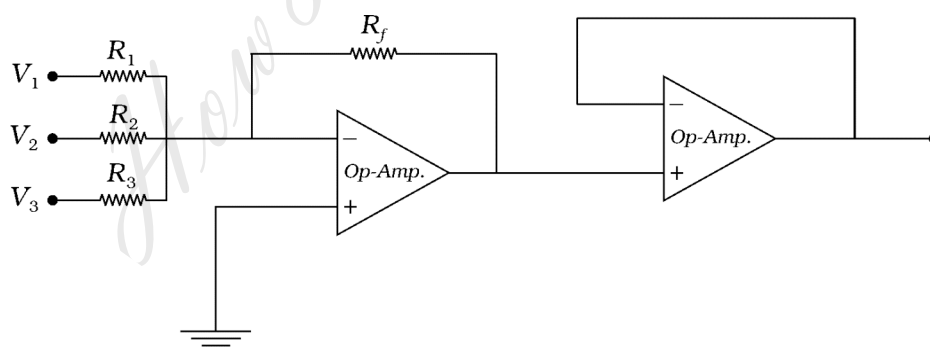

Where, $R_1 = 20 \text{ k } \Omega$, $R_2 = 40 \text{ k } \Omega$, $R_3 = 50 \text{ k } \Omega$,

$R_f = 100 \text{ } \Omega$ and $V_1 = 2 \text{ V}$

$V_2 = -1 \text{ V}$ & $V_3 = -3 \text{ V}$.

b) Write the Ideal characteristics of an ideal op-amp. 4 + 2

[Turn over

Code No. 40

6

36. a) With a neat circuit diagram, explain the working of RC phase shift oscillator.

b) Calculate the frequency of a tuned circuit. Given $L = 10 \text{ mH}$ and $C = 0.01 \text{ }\mu\text{F}$. 4 + 2

37. a) An FM wave has carrier frequency of 50 MHz, frequency deviation 10 kHz by modulating signal of frequency 5 kHz.

If the amplitude of unmodulated carrier is 20 volts, write the equation of FM wave.

b) Distinguish between AM and FM. 4 + 2

38. a) Using K-map simplify the expression

$$f(ABCD) = \sum m(0, 4, 5, 8, 12)$$

and draw logic circuit for simplified expression using basic gates.

b) Define the following :

i) Selectivity

ii) Fidelity. 4 + 2

39. a) Draw the circuit diagram of DTL NOR-gate and explain its working. Write its truth table.

b) Express $\overline{A} + \overline{B}$ in canonical sop form. 4 + 2

40. Draw the block diagram of TV receiver and explain its working with each block. 6

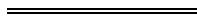

HowToExam.com

[Turn over