

FMSMOCKTEST

Instructions

1. DO NOT OPEN THE SEAL OF THIS BOOKLET. WAIT FOR THE SIGNAL TO START.
2. This booklet contains 24 pages including the blank ones. Immediately after opening the booklet, verify that all pages are printed properly.
3. Keep only the Admit Card, pencil eraser and sharpener with you. DO NOT keep with you books, rulers, slide rules, drawing instruments, calculators (including watch calculators), pagers, cellular phones, or any other device. These should be left outside the room.
4. This paper has 150 questions. The total time for the test is 120 minutes.
5. The paper is divided into five sections.
 - Section-I : 30 Questions
 - Section-II : 30 Questions
 - Section-III : 30 Questions
 - Section-IV : 30 Questions
 - Section-V : 30 Questions
6. Directions for answering the questions are given in the test booklet before each group of questions to which they apply. Read these directions carefully and answer the questions by darkening the appropriate ovals.
7. Wrong answers carry negative marks. There is only one correct answer for each question.
8. Do the rough work on the test booklet only and NOT on the answer sheet or any other paper.
9. Follow the instructions of the invigilator. Candidates found violating the instructions will be disqualified.
10. At the end of the test, remain seated. Do not leave the hall till the invigilator announces, "You may leave now." The invigilator will make the announcement only after collecting the test booklets and answer sheets from everyone in the room.

ANY CANDIDATE GIVING/SEEKING/RECEIVING ASSISTANCE OR FOUND COPYING WILL BE IMMEDIATELY DISQUALIFIED.



Section – I

Direction for questions 1 to 30: Read the following passages and answer the questions that follow.

Passage – 1

The scene is fairly familiar at first. The lights dim, and an eerie squeal of flutes silences the rustle and buzz of the audience. The first actor enters, attired in full Kabuki dress and pandemonium erupts in the crowd. Men bellow through cupped hands. To a foreigner the reaction seems a little harsh: the poor man has yet to utter a single line. However, no ushers appear to clear the stalls and soon everyone settles down to listen to the opening speech. Then another actor enters and ka boom — the hecklers start again, leaning forward to scream at the newcomer. Strangely, he appears pleased. Evidently I'm missing something.

The English commentary in my earphones soon confirms that I am. Such outbursts are expected, the voice explains, even demanded in Japanese theatre. The audience is calling out the actors' names, and the greater the performer's standing the higher the roof is raised. Forget the sharp 'sshhh!' that greets any interruption in a Western theatre. Fans are supposed to shout here. Keeping your mouth shut is almost rude.

If you were to listen to the dinner party talk from Beijing to Bangalore, you might think theatre was all but dead in Asia. The occasional touring production or big musical — *Cats*, *The Phantom of the Opera*, *Les Miserables* and now *Miss Saigon* — offers glimpses of Broadway or London's West End. But outside the dull conservatism of national troupes or small-scale experimental groups, the culture vultures say pickings are slim.

Not so in Tokyo, the theatrical centre of the East. Simultaneous English translations and programme notes make traditional shows easy to follow. And in the Ginza district, the heart of Tokyo's theatreland, audiences can catch not only Kabuki but also Japanese productions of Bernstein, Beckett, Shakespeare and Gilbert and Sullivan.

Part of the fun of watching Western classics such as *42nd Street* is observing how Japanese portray foreigners. It's like seeing yourself in a fairground Hall of Mirrors: the image is familiar, but amusingly distorted. Wearing blond wigs and remembering not to bow in greeting, the actors nonetheless sometimes resort to peculiarly Japanese gestures: signalling 'Me' by pointing fingers to their noses and hiding laughter by pressing their palms to their faces. The five troupes of the Takarazuka Grand Theater company, opposite the Imperial Hotel, have a staggering repertoire from *West Side Story* to *Hamlet* and perform their own dramatizations of Hemingway's *For Whom the Bell Tolls* and Tolstoy's *War and Peace*. The male leads are romantic and clean-cut, strong yet sensitive, not least because they are played by women. The mobs of female fans that crowd the stage door after the show bear witness to how poorly Japanese men apparently measure up to this ideal. Its recent productions include *Gone with the Wind*, *Jekyll and Hyde* and *Fiddler on the Roof*.

Even Kabuki is getting accessible. The Ichikawa family's Super Kabuki company has reinvented the genre for modern audiences by featuring special effects that wouldn't be out of place in Hollywood. In *Shin Sangokushi*, a real waterfall as wide as the stage is the backdrop for a hair-raising battle to the death. Spectators in one corner are given plastic capes to protect themselves from the victor's splashy triumph. In another scene, a doomed ship floats on a sea of dry ice — its crew writhing in flames of flickering red light before breaking in two



and plunging through the stage with a groan worthy of the Titanic. Taped commentaries offer whispered guides to the complicated and often racy plots. The Tourist Information Center will tell you where the company is playing. Or try the more traditional and world-famous Kabuki-za at the Ginza stop on the Hibiya subway, which also features English commentaries. But be warned: Kabuki-za's epics can each run to five hours.

After the show, Ginza offers Tokyo's finest and (most expensive) sushi, at up to \$300 a head. But just as authentic and considerably cheaper is the alfresco Yurakucho Yakitori Alley, where \$30 will buy a meal of some of the capital's best grilled chicken, beef or seafood. The area is under the Shinkansen line and a stroll from most theatres. Call it 'Bullet Trains over Broadway'.

1. A foreigner finds the reaction of a crowd to the entry of an actor as harsh because
 - a. the actor has not yet demonstrated his talents to the crowd for their judgment.
 - b. the author could not hear a word of what was going on.
 - c. the author could not understand the regional language.
 - d. the opening speech was drowned in the pandemonium that ensued.
2. The word 'alfresco' in the passage refers to
 - a. a wall painting.
 - b. a cheap eating-joint.
 - c. an open air eating place.
 - d. None of these
3. The word 'sshhh' in the passage implies that
 - a. the author was not happy to witness the chaos in the Japanese theatre.
 - b. Western audiences are not very demonstrative when it comes to appreciating the theatre.
 - c. interruptions are not welcome in Western theatres.
 - d. None of these
4. How does the author react to the duration of the Kabuki-za epic?
 - a. He is elated.
 - b. He is doubtful whether one can stay that long.
 - c. He prefers one-act plays.
 - d. Cannot say
5. With the term '...pickings are slim', the author wishes to convey that
 - a. theatre thrives in Asia.
 - b. the big musicals boasts of a large audience.
 - c. theatre is not very active in Asia.
 - d. theaters do not make enough money to cover expenses and so they totter on the way.
6. The plastic capes were given to part of the spectators
 - a. to ensure that the spectators are able to protect themselves from extreme hooliganism.
 - b. to generate special effects for the drama.
 - c. to protect the spectators from the water splashing around in the finale.
 - d. so that they can avoid the glare of the arc-lights.



7. What is the author's reaction to the way the Japanese portray foreigners in Western classics?
 - a. He finds it derisive.
 - b. He thinks that the Japanese are being patronizing.
 - c. He is amused.
 - d. He feels that they are making a mockery of the Western culture.

8. The author feels that the Japanese men
 - a. match the Japanese women stroke by stroke.
 - b. are romantic and callous.
 - c. do not measure up to the ideal male leads in the theatre.
 - d. are lapping up all the lead roles.

9. The recent productions of the Takarazuka Grand Theater company do not include
 - a. *Pride and Prejudice*.
 - b. *Gone with the Wind*.
 - c. *Fiddler on the Roof*.
 - d. *Jekyll and Hyde*.

10. The word 'repertoire' in the passage means
 - a. lead roles.
 - b. collection of plays.
 - c. place of performance.
 - d. None of these

Passage – 2

When we remember President Franklin D. Roosevelt's leadership after the Japanese attack on Pearl Harbor, we tend to think of the famous response that he carefully dictated to his secretary, punctuation included: "Yesterday comma December 7 comma 1941 dash a date which will live in infamy . . ." Yet the President's leadership was most sorely tested not on the Sunday of the surprise attack or the Monday he delivered his address but in the long, difficult days that followed. Then as now, America's sense of territorial invulnerability had been shattered. Rumours swirled: the Japanese were planning to bomb Los Angeles, were already bombing San Francisco. There was real fear, not just among the public but also within the government, that Japan might invade the American mainland, whose defences were weakened by the crippling of the Navy.

The differences between Pearl Harbor and last Tuesday's attack are abundant. At Pearl Harbor, the Japanese targeted a military base; last week the terrorists targeted ordinary civilians travelling in the air, working in their offices, walking on the streets. Then, unlike today, we faced discrete, known enemies. But Pearl Harbor, and America's larger history, teaches us that at these crucial junctures, resolve and unity are powerful weapons against despair and hysteria.

After Pearl Harbor, symbolic acts were as significant as physical preparation for war. Franklin and Eleanor Roosevelt worked together to demonstrate that the war overseas would be won only by preserving American liberty at home. The week after the raid, the Secret Service suggested a list of security measures at the White House: camouflaging the building, placing machine guns on the roof, covering the skylights with sand and tin. Roosevelt rejected most of the suggestions, to show that the capital stood unbowed — much as, a century earlier, Abraham Lincoln insisted that the construction of the Capitol dome be completed in the midst of the Civil War. Similarly, on Tuesday President Bush decided to end the day in Washington rather than in a NORAD bunker. On Friday he presided over a national day of prayer, giving prominent roles to people of all races and creeds, including a Muslim religious leader.



Eleanor, visiting the West Coast after Pearl Harbor, bore witness to the hysteria directed against Japanese Americans. Government officials swooped down upon Japanese banks, stores and houses. Swimming against the tide of prejudice, Eleanor antagonized many Californians when she called for tolerance and posed for a picture with US born Japanese Americans; the editorial board of *The Los Angeles Times* reacted angrily and called for her forcible retirement from public life. The First Lady responded that more than fairness was at stake: "Almost the biggest obligation we have today is to prove that in a time of stress we can still live up to our beliefs." Though the US later let that principle down with the internment camps, it remains a valuable point to remember, particularly if images of Palestinians celebrating the attacks inflame anger at Arab Americans here.

In many ways, the challenge facing George W. Bush is greater than Roosevelt's. F.D.R. was an immensely popular third-term president who had led America through the Great Depression. And he had the luxury of immediate, concrete action that galvanized Americans in the days and weeks after the attack. There were weapons to be built, resources to be conserved, a military force to assemble. This week, outside Washington and New York City, there was little more for most Americans to do than give blood.

But the crisis today makes such mundane acts heroic. Terrorism seeks to turn ordinary life into a battlefield, and the bravest act Americans can undertake in the coming weeks is to go about their daily lives, ride airplanes and elevators and do what the British did during the Blitz, show up at work every morning. Today, Bush has the opportunity to draw on something we rarely experience: the feeling that America is not merely an abstraction but an entity of which we are each a vital part.

On Christmas Eve 1941, over the objections of the Secret Service, F.D.R insisted on lighting the White House Christmas tree. It made a memorable night for the fifteen thousand people who gathered to hear him speak, illumined by a crescent moon, the red light of the Washington Monument and the glow of the tree. While we prepare to strike back against terrorism and secure our skies and our homes, the challenge to our leaders and to all of us is to show that no terrorist group will be allowed to extinguish the beacons of freedom and democracy.

11. Roosevelt's leadership evokes memories of his famous response because
 - a. Pearl Harbor was attacked on December 7, 1941.
 - b. he delivered his address in parliament and asked Congress for a declaration of war.
 - c. America's invincibility came under question during his tenure.
 - d. the response is now inevitably linked to his tenure during the attack on Pearl Harbor.

12. The word 'beacons' is used in the passage to convey
 - a. that no one can take away America's right to freedom.
 - b. the safety of the skies were taken for granted before the Pearl Harbor attack.
 - c. that the torch of freedom and democracy shall not be extinguished.
 - d. None of these

13. How were the enemies of the Pearl Harbor attack different from the enemies of the Tuesday attack?
 - a. The enemies in the former case were unknown and the enemies of the Tuesday attack were identified terrorists.
 - b. The enemies in the former case were untrained and the enemies of the Tuesday attack were experts.
 - c. The enemies in the former case were identifiable and the enemies of the Tuesday attack were faceless.
 - d. None of these



than its growth expectations of 16% and way above the 10-25% averaged by the 60,000 other outlets that retail Lakme's colour cosmetics sans advisors.

Cosmetics major Lakme's theory that adding a service dimension to the brand would increase sales is beginning to pay off. And it is taking a quantum leap forward by entering the Rs. 500 crore beauty salons business. It has 32 full fledged salons around the country; four of these have been around since the seventies and the rest have come up in the last one year. It now plans to roll out another 200 over the next three years. That will make it one of the world's largest beauty salon chains. In fact, HLL's foray into the services business, the laundrette pilot and home delivery (Sangam Direct), was also promoted by the Lakme experience.

So why did this FMCG company enter services? Lakme's position as market leader was threatened when international majors like Revlon and Maybelline entered the fray in the mid-90s. Lakme realised it had to do something fast to retain its 60 per cent market share. It launched Elle 18 (a lower-priced brand targeted at teenagers). And figured that point-of-sale push would help. Thus, the beauty advisor idea emerged.

Tabassum's presence behind the counter and the interaction she brings into the consumer's purchase experience turned out to be a key sale clincher in the Rs. 500 crore colour cosmetics category that is largely driven by impulse purchases. The advisors gave Lakme a direct information channel for consumer preferences and offtake, among other things. This helped the company cut inventory by about 40 per cent, while maintaining its S.K.U. (stock keeping unit) strength of 185. No specific numbers are available, but going by the industry's average inventory holding of about 16-20 weeks along the supply chain, Lakme saves around Rs. 15-20 crores. Sure, its stockout rose from three to five per cent, but counters Anil Chopra, business head at Lakme Lever, the savings from the inventory cuts more than offset this loss. Advisors also cost Lakme little; they are employed by the distributors; Lakme only indirectly subsidises the cost. The risk of failure, too, is low: an advisor can be replaced easily. And the model is scaleable.

No wonder Lakme Lever is rolling out the beauty advisor concept. The idea is to have them man outlets with monthly sales of Rs. 25,000 plus. Of the 600 nationwide outlets that fit the bill, advisors remain to be placed in 210. This could take another year.

"Consumers like and even expect a certain amount of hand-holding in choosing cosmetics," says Inder Madhan, GM, Lifespring, a health and beauty chain. Others like Modi Revlon have employed this strategy to even better effect, "We have seen our sales go up by 50 per cent whenever we place a beauty advisor in an outlet. Revlon is the best selling brand in all the stores that we have a beauty advisor in," claims Umesh Kumar Modi, CEO, Modi Revlon. Nevertheless, none have adopted a scale as large as that of Lakme's. Modi plans to increase the number of advisors by 50 per cent this year, to a total of only 500 in two years. It also does not plan to set up any beauty salons here, unlike in the international markets where Revlon has outlets, albeit on a small scale.

So what does Lakme see in salons that others don't? Chopra expects the Indian market to grow at 20 per cent annually to touch Rs. 1,000 crore in four years. "There are 4,936 salons in Delhi alone, about 11 per cent of which are in the A+ (super premium) category, and 20 per cent are in the B+ and B categories," says Rohit Sood, vice president (marketing), Brushman India, the marketing partner of Dutch hair cosmetics giant Keune, which is setting up 80 haircare salons in the next three years. If each salon in Delhi makes an average of Rs. 500 a day (premium brands like Keune expect Rs 2,000 per chair per day) the Delhi salon market could be worth Rs. 75 crore a year. Demand, too, is growing, given the 25 million-odd middle- and upper-class working



women in India who are becoming increasingly conscious of their looks. Profit margins are also good: Lakme can net 25-30 per cent (almost double the margins made selling cosmetics) through the franchisee model.

According to the Global Salon Panels India 2001 report, published by Diagonal Reports, an Ireland-based market intelligence research firm, 80 per cent of the 1,000 salons that were polled used Wella (an international brand), 60 per cent used L'Oreal and 40 per cent used brands like Avon, Ayur and Shahnaz Hussain, among others. Lakme and HLL were not among the most preferred. Sales has to be pushed at the salons, but Lakme figured it could do better. It decided to set up its own business. "We wanted to create an alternative channel," says Chopra.

Each salon will have a standardised format: 2,000 square feet space costing about Rs. 20 lakh (excluding real estate). Some of the salons will be company owned; most of the new ones will be franchised. The model has been perfected in smaller cities including Pune, Indore, Vadodara, Ludhiana and Jalandhar. Lakme will provide the technical expertise; investments in real estate and operations will be made by the franchisee.

Cosmetics firms have succeeded in the salons business abroad. UK-based Toni and Guy, which makes haircare products and runs 150 hair salons, is the best example. For Lakme to succeed, it has to first iron out a few glitches.

First is reach. Few people visit salons that are not in their neighbourhood. Can Lakme get that kind of reach in all the major cities? Unlikely, in the short-term. "Some sort of an alliance or co-branding with the salons that already exist may, perhaps, have been a better strategy," argues Keune's Sood. Second is positioning. "The general perception is that company-owned salons are expensive. Though Lakme beauty salons are reasonably priced, it has not been communicated well enough," says the business head of an upmarket salon chain.

Once sorted out, salons can also fuel the growth of HLL's hair-care brands. "Currently, about 10 per cent of our salons' total billings are product sales. This could go up to 20 per cent," says Chopra.

Most significant though will be the impact on Lakme's bottomline. By going for franchises, Lakme avoids large capital investments and recurring expenditure. Yet, it will get 20 per cent of the salons' billings as franchise fees. If the business grows big enough to contribute 25-30 per cent of sales 2004 onwards (from the current five per cent levels) as Chopra hopes, it could even contribute one-third to one-half of Lakme's profits. And that's why Lakme is donning the war paint.

21. Which of the following statements is supported by the passage?
 - a. Beauty advisors grew Lakme's sales by 42 per cent in the last festive season.
 - b. Lakme had a growth expectation of 16 per cent in the last festive season.
 - c. Retail outlets grew Lakme's sales by 10-25 per cent in the last festive season.
 - d. None of the above

22. The author uses the term 'donning the war paint' to convey that
 - a. Lakme is on the warpath with HLL hair-care brands.
 - b. Lakme is making an all-out effort to up its profits through the franchising route.
 - c. Lakme is focusing only on colour cosmetics at the moment to paint the town red.
 - d. None of the above



23. We can infer from the passage that
- Lakme's plans of making itself into one of the world's largest beauty salon chains would remain a pipeline dream.
 - Lakme's four beauty salons that existed from the seventies have not been an encouraging experience.
 - Sangam Direct would not have been launched had it not been for the Lakme experience.
 - None of the above
24. The best example of a cosmetic firm that has successfully ventured into the salon business is
- Keune.
 - Modi Revlon.
 - Toni and Guy.
 - L'Oreal.
25. According to the passage, all of the following statements are true except
- beauty advisors helped Lakme cut inventory by about 40 per cent.
 - Lakme regrets that its stockouts rose from three to five per cent.
 - beauty advisors are not an expensive proposition for Lakme.
 - None of the above
26. The Global Salon Panels India 2001 report revealed all of the below except which one?
- Wella was the most preferred brand.
 - L'Oreal was used by 60 per cent of the salons polled.
 - Ayur was not left behind in the race for the preferred brand.
 - HLL was not among the preferred brands.
27. The author mentions 'consumers expect a certain amount of hand-holding' to imply that
- Lakme beauty salons have not communicated their pricing strategy accurately to the people.
 - the colour cosmetic customer has no clue as to how to enhance her beauty through makeup.
 - consumers prefer expert guidance in buying the right cosmetics.
 - customers are easy prey for a smooth-talking saleswoman.
28. A suitable topic for the passage would be
- Lakme — Leading the Cosmetic Market.*
 - Salon Business to the Rescue.*
 - Beauty Tips Boost Lakme Sales.*
 - Lakme Enters the Service Sector.*
29. Approximately, what percentage of Delhi salons falls in the super premium category?
- 20 per cent
 - 21 per cent
 - 11 per cent
 - 25 per cent
30. What made Lakme take action to retain its market share?
- Teenagers did not show much interest in cosmetics.
 - Lakme's brand equity was eroded by the failure of salons business.
 - Franchise models tried out in smaller cities flopped in big metros.
 - Lakme felt the threatening presence of international leaders like Revlon.

Section – II

Direction for questions 31 to 35: Choose the correct synonym for the given word from the four alternatives.

31. Amass
a. Go to church b. Attend a sermon c. To gather a lot of d. Heavy
32. Discreet
a. Separate b. Careful c. Sly d. Mischievous
33. Cortege
a. Procession b. Race c. Bridal gown d. Lace
34. Forestall
a. Mark b. Purchase c. Regret d. Prevent
35. Colossal
a. Loss b. Huge c. Exceed d. List

Direction for questions 36 to 40: Choose the correct antonym for the given word from the alternatives provided.

36. Illicit
a. Unlawful b. Legalize c. Cheat d. Lawful
37. Flawed
a. Peculiar b. Perfect c. Compliant d. Fleece
38. Jarring
a. Disturbing b. Shock c. Pleasant d. Stifling
39. Peril
a. Safety b. Disregard c. Dangerous d. Pure
40. Teetotaler
a. Priestly b. Lavish c. Alcoholic d. Tiresome

Direction for questions 41 to 45: Choose the one-word from among the given choices that can act as a substitute for the given definition.

41. An image or thing that is important or impressive because it is a symbol of something:
a. Cynosure b. Iconic c. Grand d. Majesty



42. To consider and talk about each detail of a theory or a situation:
a. Gossip b. Moot c. Dissect d. Ponder
43. All the traditions of a country that has continued for many years and have been passed on from one generation to another:
a. Heritage b. Moribund c. Orthodox d. Conservative
44. Goods of a higher than usual quality and often expensive:
a. Pricey b. Bauble c. Meretricious d. Premium
45. A narrow piece of decorated cloth or twisted threads, which is used to decorate clothes or curtains:
a. Relay b. Braid c. Warp d. Weft

Direction for questions 46 to 50: Complete the sentences given below by selecting the appropriate choice from among the given alternatives.

46. Washington is ___ to prepare its people for a prolonged retaliatory strike.
a. stepping down efforts b. stepping up effort
c. stepping up efforts d. stepped up efforts
47. When we do survive, ____ .
a. we realize now truly wonderful life is b. we realize how wonderful, truly is life
c. we realize how truly wonderful life are d. we realize how truly wonderful life is
48. It's a pity ___ selfish, ungrateful person inside.
a. which most people see only your good-looking exterior and not the
b. that most people see only your good-looking exterior and not the
c. that most people see only your good-looking exterior and the not
d. that most people see only your good-looking exterior and not
49. We must be guided by ___ mere revenge.
a. higher goals than b. higher goals than by c. higher goals d. higher goal than
50. Give yourself permission ___ boredom or irritation.
a. to feel what you're feeling, the professionals urge, even if it's
b. to feel what you're feel, the professionals urge, even if it's
c. to feel what you're feeling, the professionals urges, even if it's
d. to feel what you're feeling, the professional urge, even if it's

Direction for questions 51 to 55: Select the appropriate pair of words from among the given choices that parallels the relation in the given pair of words in the question.

51. Nemesis : Punishment
a. Revenge : Likely b. Rationality : Logic
c. Reason : Infamy d. Paragon : Crisis



52. Hack : Carve
a. Grind : Polish
c. Gouge : Engrave
b. Whet : Blunt
d. Snip : Mince
53. Slur : Speech
a. Smudge : Writing
c. Confuse : Puzzle
b. Erase : Drawing
d. Decrease : Volume
54. Prairie : North America
a. Steppe : Croatia
c. Chateaux : France
b. Villa : Burgundy
d. Tropic : Bahamas
55. Hindsight : After
a. Premonition : Before
c. Judgment : Conceited
b. Foresight : Condition
d. Descry : Tantalize

Direction for questions 56 to 60: Pick out the word from among the given choices that has the correct spelling.

56. a. Awowed b. Avoved c. Avowed d. Evowed
57. a. Strolle b. Stroll c. Strol d. Astroll
58. a. Pendemonium b. Pandemonuim c. Pandaemonium d. Pandemonium
59. a. Tattoos b. Tatoos c. Tattos d. Tattooz
60. a. Predecesors b. Predecessors c. Predesessors d. Predecessers



Section – III

61. Dashing Bhaskar can stuff valentine cards into envelopes at a rate of 45 envelopes per minute while Dynamic Lajwanti takes 1.5 min to stuff the same number. Working together, how much time will they take to stuff 300 envelopes?
a. 3 min b. 3.5 min c. 3.75 min d. 4 min
62. On a certain day, Rohit started with p newspapers. From morning to noon, he sold 40% of the papers, and between noon and evening he sold 60% of the remaining. Then he realised that had he sold double the number of newspapers than he sold in the afternoon, he would have had to borrow 12 papers from another vendor. Find p .
a. 108 b. 100 c. 96 d. 72
63. If $a\%$ of b is c , $b\%$ of c is a and $c\%$ of a is 1, then which of the following is not true?
a. $a = 10$ b. $b = 100$ c. $a = c$ d. $a = b$
64. If n is an integer between 0 and 100, then any of the following could be $3n + 3$ except
a. 300 b. 297 c. 208 d. 63
65. Suvakar charges interest on his lendings at 20% SI per annum. However, the interest is payable in the beginning of each half-year. The effective half-yearly simple rate of interest would work out to be
a. 11.11% b. 10.5% c. 22.22% d. None of these
66. If $\log_{10} a$, $\log_{10} b$ and $\log_{10} c$ are in AP, then a , b , c must be in
a. AP b. HP c. GP d. both AP and GP
67. If $\log_r p = 2$ and $\log_r q = 3$, then what is the value of $\log_p q$?
a. $\frac{3}{2}$ b. $\frac{1}{6}$ c. 6 d. $\frac{2}{3}$
68. Rashmi started a business with Rs. 4,500 and Pratima joined afterwards with Rs. 3,000. If the profits at the end of one year were divided in the ratio 2 : 1 respectively, how many months later did Pratima join the business after the start?
a. 1.5 b. 2 c. 3 d. 4.5
69. Kunjumol's bag contains 800 coins of 25-paisa denomination and 1,200 coins of 50-paisa denomination. If 5% of 25-paisa coins and 25% of 50-paisa coins are removed, the percentage of money removed from the bag is
a. 30% b. 20% c. 17.8% d. None of these
70. A company manufactures two products X and Y. One unit of X requires 3 units of material A and 2 units of material B while one unit of Y requires 2 units of material A and 5 units of material B. If 25 units of each product were to be produced, calculate the requirement of material B.
a. 175 b. 125 c. 150 d. None of these



71. It costs Rs. 10,000 to make the first thousand copies of a book and x rupees to make each subsequent copy. If it costs a total of Rs. 72,300 to make the first 8,000 copies of the book, what is the value x ?
 a. Rs. 8.90 b. Rs. 8.75 c. Rs. 89 d. None of these
72. Each time Princy smiles at Komal, she is rewarded Rs. 20 and each time she quarrels with Komal, she pays a penalty of Rs. 15. If this sequence of smiling and quarrelling continues, in how many sequences does Princy reaches the figure of Rs. 60 for the first time?
 a. 8 b. 9.5 c. 12 d. 9
73. Find a and b such that $(x + 1)$ and $(x + 2)$ are factors of the polynomial $x^3 + ax^2 - bx + 10$.
 a. 8 and -17 b. 17 and -8 c. -9 and -1 d. None of these
74. Given are the lengths of the sides and a diagonal of quadrilateral ABCD as shown below. Find its area and length of the other diagonal.

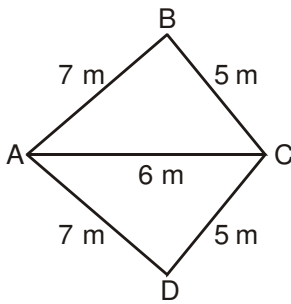

- a. $6\sqrt{5}, 5\sqrt{6}$ b. $6\sqrt{6}, 4\sqrt{6}$ c. $12\sqrt{6}, 4\sqrt{6}$ d. $12\sqrt{6}, 5\sqrt{6}$
75. Sanjay Veer is a land surveyor. One day he records the following details in his notebook. What is the area of the land surveyed? (All readings are in metres.)

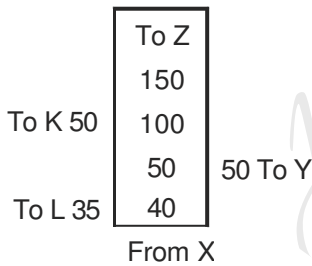

- a. 7,000 m² b. 7,500 m² c. 8,250 m² d. 6,000 m²
76. The wages received by A, B and C together amount to Rs. 144. If A works for 10 days, B for 12 days and C for 15 days, then the amount received by A, when the proportion of their daily wages is $\frac{1}{2} : \frac{1}{3} : \frac{1}{5}$, is
 a. Rs. 60 b. Rs. 48 c. Rs. 90 d. None of these



77. What is the least number which must be added to 299 to make the sum a perfect square?
a. 30 b. 27 c. 20 d. None of these
78. What must be the least number of the students in a group such that they can be arranged in lines of 10, 15 and 25 independently and can also be arranged in a square as a group?
a. 600 b. 900 c. 3,600 d. None of these
79. Ammar drives his car twice the speed of an auto. One day he drove the car for 10 min and the car broke mid-way. He left the car and took an auto to reach the office. It took him 30 min from there to reach the office. What would be the total time taken by car to reach his office?
a. 25 min b. 20 min c. 27 min d. 36 min
80. The angle of elevation of a patch of cloud from a point x metres above the surface of a pool is 30° and the angle of depression of its reflection is 60° . What is the height of the cloud patch above the surface of the pool?
a. $\sqrt{2}x$ m b. $2x$ m c. x m d. $\frac{x}{\sqrt{3}}$ m
81. If $x^a = y$, $y^b = z$ and $z^c = x$, what is $\frac{1}{abc}$?
a. xyz b. $(xyz)^{abc}$ c. 1 d. None
82. Two bullock carts move in the same direction from the same place at the rate of 4 km/hr and 4.5 km/hr respectively. What time will they take to be 8.5 km apart?
a. 1 hr b. 3 hr 50 min c. 17 hr d. 13 hr 15 min
83. A train leaves from Meerut at 7 a.m. and reaches Delhi at 11 a.m. Another train leaves from Delhi at 9 a.m. and reaches Meerut at 12.30 p.m. At what time do the two trains cross each other?
a. 9.56 a.m. b. 10.36 a.m. c. 10.56 a.m. d. 11 a.m.
84. If x men working x hours a day can do x units of a work in x days, then y men working y hours per day in y days would be able to complete how many units of work?
a. $\frac{x^2}{y^3}$ b. $\frac{x^3}{y^2}$
c. $\frac{y^2}{x^3}$ d. $\frac{y^3}{x^2}$
85. If $f(x) = 1 + x + \frac{1}{x}$, what is $f\left(\frac{1}{x}\right) + f(x)$?
a. $f(x) - f\left(\frac{1}{x}\right)$ b. $f\left(\frac{1}{x}\right) - f(x)$
c. $2f\left(\frac{1}{x}\right)$ d. $[f(x)]^2$



86. $\int 4^x \cdot 3^x \cdot e^x dx = ?$

a. $\frac{4^x \cdot 3^x \cdot e^x}{\log_e 12} + C$

b. $\frac{(7e)^x}{\log_e (7e)} + C$

c. $\frac{4^x \cdot 3^x \cdot e^x}{2\log_e 2 + \log_e 3 + 1} + C$

d. None of these

87. Integrate $\int \frac{(x^2 + x^5)}{1 + x^6} dx$.

a. $\frac{1}{3} \left[\frac{1}{2} \sqrt{1+x^3} + \frac{1}{2} \sin^{-1} x \right] + C$

b. $\frac{1}{3} \left[\left(\frac{1}{2} \log_e |x^6 + 1| \right) + \tan^{-1} x^3 \right] + C$

c. $\frac{1}{3} \log_e |x^6 + 1| + \tan^{-1} x^3 + C$

d. None of these

88. The average salary of female employees in a company is Rs. 5,000 and that of male is Rs. 6,000. The mean salary of all the employees is Rs. 5,700. Find the percentage of male and female employees respectively.

a. 30% and 70%

b. 70% and 30%

c. 55% and 45%

d. None of these

89. If $y = (\sqrt{x})^{(\sqrt{x})^{(\sqrt{x})}}$, then $\frac{dy}{dx}$ is

a. $\frac{y}{x(1-\log x)}$

b. $\frac{y^2}{x(1+y \log x)}$

c. $\frac{y^2}{x(2-y \log x)}$

d. None of these

90. $\lim_{x \rightarrow 0} \frac{\tan x + \sin x}{x}$ is equal to

a. 2

b. 0

c. 1

d. None of these

91. $\lim_{x \rightarrow c} \frac{c^x - 2x^c}{x^x - c^c} = -2$, then

a. $c = 2$

b. $c = 4$

c. $c = 1$

d. None of these

92. The mean of 10 numbers 2, $x + 5$, $x + 6$, $x + 8$, $x + 9$, $x + 11$, $x + 12$, $x + 14$, $x + 15$ and 24 is 17. Then find the value of x .

a. 7

b. 9

c. 8

d. None of these

93. If $y = \log \left[\sin^{-1}(\sqrt{x}) \right]$, then $\frac{dy}{dx}$ is

a. $\frac{1}{2\sqrt{x(1-x^2)} \sin^{-1} x}$

b. $\frac{1}{2\sqrt{x} \sqrt{1-x} \sin^{-1} x}$

c. $\frac{\sqrt{x}}{2\sqrt{1-x} \sin^{-1} x}$

d. None of these



94. If one root of quadratic equation $px^2 + qx + r = 0$ is equal to the 4th power of the other, then
 a. $p^{\frac{4}{5}}r^{\frac{2}{5}} + p^{\frac{1}{5}}r^{\frac{4}{5}} + q = 0$ b. $(pr)^{\frac{1}{5}} + (pr)^{\frac{4}{5}} + q = 0$ c. $p^{\frac{4}{5}} + r^{\frac{4}{5}} = q^{\frac{4}{5}}$ d. None of these
95. How many different words can be formed with the letters of 'PUNJAB', when both P and N are together?
 a. 120 b. 240 c. 144 d. None of these
96. The area within the curve $|x| + |y| = 8$ is
 a. 32 sq. units b. 64 sq. units c. 128 sq. units d. None of these
97. There are 19 identical red balls and one black ball. In a green jar 10 balls are put and the remaining 10 balls are put in a yellow jar. What is the probability of the black ball being in the yellow jar?
 a. $\frac{9}{19}$ b. $\frac{1}{20}$ c. $\frac{1}{19}$ d. $\frac{1}{2}$

Direction for questions 98 to 102: Answer the questions based on the following information.

Unclaimed redemption and dividend amounts for TMF India Ltd.

The amount of dividends declared and redemptions made, which were remaining unclaimed as on the balance sheet data are given below.

Scheme name	Dividend		Redemptions	
	Number of unclaimed warrants	Amount (Rs. in lakhs)	Number of unclaimed warrants	Amount (Rs. in lakhs)
TIGF	170	3.26	7	0.83
TIF	1601	42.18	48	2.30
TGSF	212	17.76	4	0.15
TMIP	526	5.39	3	0.26
FIIF	—	—	0	0.00
FIBF	—	—	1	0.13
FIGF	—	—	3	0.50
Total	2509	68.59	69	4.17

98. What is the average dividend amount per unclaimed warrants across all schemes for TMF India Ltd.?
 a. Rs. 1,964 b. Rs. 2,734 c. Rs. 3,822 d. None of these
99. What is the approximate ratio of the average redemption amount per warrant in TIGF scheme to that in FIBF scheme?
 a. 10 : 9 b. 9 : 10 c. 11 : 13 d. 9 : 13



100. Which of the following statement(s) is(are) not true?
I. The total amount of unclaimed warrants for TIGF and TIIF schemes is Rs. 48.57 lakh.
II. TIIF scheme accounts for more than 60% of the total number of unclaimed warrants.
a. Only (I) b. Only (II) c. Both (I) and (II) d. Both are true
101. What is the percentage of unclaimed dividend amount in TMIP scheme?
a. 7.8% b. 5.2% c. 10.5% d. Cannot be determined
102. A scheme is given the 'star' status when it has minimum number of unclaimed warrants for that scheme, among all others. Among the given schemes, which scheme is to be awarded 'star' status?
a. FIIF b. FIBF c. TIIF d. Cannot be determined

Direction for questions 103 to 107: Each question is followed by two statements, I and II. Answer the questions using the following instructions.

- Mark**
- a. if the question can be answered by one of the statements alone, but cannot be answered by using the other statement alone.
 - b. if the question can be answered by using either statement alone.
 - c. if the question can be answered by using both the the statements together, but cannot be answered by using either statement alone.
 - d. if the question cannot be answered even by using both the statements together.

103. Is x greater than y ?
I. $x + y = 16$
II. $x + 2P = 5, y + P = 20$
104. What is the distance of the point (x, y) from the origin?
I. $x^2 + y^2 = 16$
II. $x = 4, y = 0$
105. What is the value of $x - y - z$?
I. x, y, z are either 1 or 0
II. $x^2 + y^2 + z^2 = 1$
106. What is the number k ?
I. One-fourth of the number exceeds $\frac{1}{5}$ of its succeeding number by 3.
II. k is a positive integer.
107. What is length of the side of an equilateral triangle formed by a wire?
I. The total length of the wire is divisible by 3.
II. The area of the rectangle formed by the same wire is twice the area of the square formed by the wire.



Direction for questions 108 to 112: Study the given diagram carefully and answer the questions that follow.

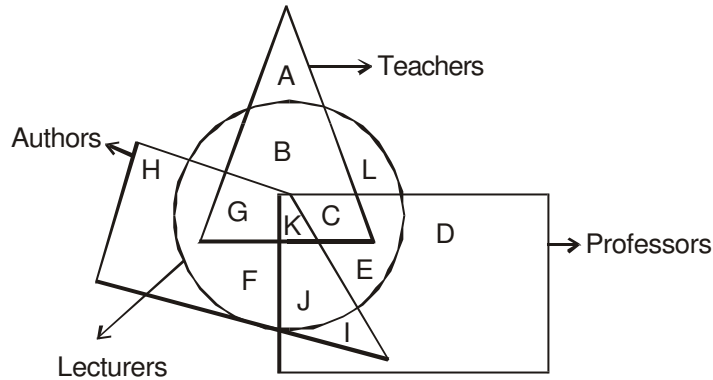

108. Which of the following represents the teachers who are professors and lecturers, but not authors?
 a. B b. E c. C d. None of these
109. 'G' represents the region of
 a. teachers who are authors and professors but not lecturers
 b. lecturers who are authors and professors but not teachers
 c. authors who are teachers and lecturers but not professors
 d. lecturers who are authors but not professors and teachers
110. Lecturers who are not authors, teachers and professors are represented by
 a. E b. F c. I d. L
111. Which of the following statement is true?
 a. B represents the region of teachers who are professors but not lecturers
 b. J represents the region of lecturers who are professors but not authors and teachers
 c. C represents the region of teachers who are professors and lecturers but not authors
 d. None of these
112. Only teachers, professors, lecturers and authors are represented respectively by
 a. A, F, D, I b. A, D, I, H c. A, D, H, I d. A, D, L, H

Direction for questions 113 to 117: Read the given information carefully and answer the questions that follow.
 Seven cars — Alto, Benz, Cadillac, Dolly, Electra, Fiat and Givo — are ranked on the basis of their performance, consecutively in a row but not necessarily in the same order.

Following data is also given.

Alto is standing in the middle of the row. Benz is as much less than Alto as Cadillac is greater than Fiat in ranking. Fiat is ranked three places less than Givo. Electra is ranked higher than Benz.

113. From right-hand side, the sixth car of the row is
 a. Alto b. Cadillac c. Benz d. Givo



Section – IV

121. Indian Television Academy's best news channel award has been won by which of the following news channels recently?
a. Star News b. Zee News c. Aaj Tak d. DD-1
122. 'Quality in everything we do' is the punchline associated with which of the following companies?
a. DHL Worldwide Express b. Ernst & Young
c. Accenture d. Novell
123. The name 'United Nations' was suggested by which of the following famous personalities?
a. Winston Churchill b. Anwar Sadat c. Jimmy Carter d. Franklin D. Roosevelt
124. East Timor, that got independence from Indonesia recently, was very much in the news. East Timor became independent on which of the following dates?
a. January 20, 2002 b. March 20, 2002 c. May 20, 2002 d. August 20, 2002
125. This airlines was in the news recently for filing bankruptcy — the biggest ever in the global aviation history. We are talking about
a. France Air b. United Airlines c. Cathay Pacific d. Lufthansa
126. Which of the following personalities has recently been appointed as the chief executive officer of the bankrupt WorldCom Inc.?
a. John Sidgmore b. Bernie Ebbers c. Michael Capellas d. Charles B. Wang
127. 'Achtung baby' and 'easy to get in, bloody tough to get out' are the famous advertisement campaigns you would associate with
a. J. Watler Thompson b. Ogilvy & Mathers c. McCann-Erickson d. Saatchi & Saatchi
128. Jerry Young and David Flio are associated with the foundation of which of the following companies?
a. Seiko b. Google
c. Intel d. Yahoo
129. Which of the following world bodies was the outcome of Uruguay round of talks (1986-94)?
a. European Union b. World Economic Forum
c. World Trade Organisation d. International Monetary Fund
130. Which of the following famous inventors of all time is associated with the establishment of the world's most admired company GE?
a. Albert Einstein b. Benjamin Franklin c. Thomas Alva Edison d. Michael Faraday
131. Winner of Miss World 2002 title, held recently, is
a. Marina Mora Montero b. Natalia Peralta c. Agbani Darego d. Azra Akin



132. Which of the following personalities is the architect of the Eiffel Tower?
a. Gustavo Eiffel b. Cesar Pelli c. Mauroice Koechlin d. Stephen Sauvestre
133. Which of the following personalities has won the prestigious Lal Bahadur Shastri National Award for excellence in public administration and management sciences for 2001 recently?
a. Deepak C. Jain b. Vijay Mahajan
c. N. R. Narayana Murthy d. Azim H. Premji
134. This person is the winner of 'Asia Business Leader' award by CNBC Asia Pacific and TNT channels recently. Identify him from the given options.
a. B. Ramalinga Raju b. S. Ramadorai c. Nandan M. Nilekani d. Arun Jain
135. Apparel brand 'Color plus' has recently been acquired by which of the following garments major?
a. Raymods Ltd. b. S. Kumars c. Madura Garments d. None of these
136. Which of the following represents India's final rank in the recently concluded Busan Asian Games 2002?
a. 6th b. 7th c. 8th d. 9th
137. What was India's rank in the Global Competitiveness report 2002 by World Economic Forum?
a. 35 b. 48 c. 57 d. 65
138. According to a recent report by Transparency International, which of the following represents the least corrupt nation of the world?
a. Norway b. Finland c. Germany d. Singapore
139. Miss Universe 2002 event took place at which of the following places?
a. London b. Abuja c. San Juan d. Caracas
140. The UN high commissioner for human rights presently is
a. Mary Robinson b. Sergio Vieira de Mello
c. Kevin Warwick d. Koichiro Matsuura
141. Which of the following banks was in the news recently as it has launched tax free bonds at seven per cent rate of interest?
a. IDBI Bank b. State Bank of India
c. Reserve Bank of India d. ICICI Bank
142. UN conference on sustainable development took place at ____ recently.
a. Durban b. Johannesburg c. Rio de Janeiro d. New York
143. Which of the following represents the number of countries in the European Union that have 'Euro' as their common currency?
a. 10 b. 11 c. 12 d. 13



144. 'International Literacy Day' is observed every year on ____ throughout the world.
a. August 27 b. November 17 c. September 8 d. December 3
145. The winner of ICC Champions Cricket Trophy held at Colombo in September 2002 was
a. South Africa b. India
c. Sri Lanka d. India and Sri Lanka jointly
146. Who won the men's single's title of Wimbledon 2002 tournament?
a. Pete Sampras b. Albert Costa c. Lleyton Hewitt d. Marat Safin
147. According to a survey conducted by ORG-MARG, which of the following is the most trusted brand in the year 2002?
a. Colgate b. Lux c. Dettol d. Britannia
148. The present Cash Reserve Ratio (CRR) is
a. 6.25 per cent b. 5.5 per cent c. 4.75 per cent d. 4.5 per cent
149. Which of the following is the name of the prepaid mobile service launched by BSNL recently?
a. Cell One b. Excel c. Dolphin d. Talkie
150. *Who Says Elephants Cannot Dance* is the title of a book authored by the former chief of which of the following IT giants?
a. Intel b. Microsoft c. IBM d. Oracle



FMS - Mock

Answers & Explanations

1	a	2	c	3	c	4	b	5	c	6	c	7	c	8	c	9	a	10	b
11	d	12	c	13	c	14	b	15	d	16	d	17	d	18	d	19	c	20	b
21	d	22	b	23	c	24	c	25	b	26	d	27	c	28	d	29	c	30	d
31	c	32	b	33	a	34	d	35	b	36	d	37	b	38	c	39	a	40	c
41	b	42	c	43	a	44	d	45	b	46	c	47	d	48	b	49	b	50	a
51	b	52	c	53	a	54	c	55	a	56	c	57	b	58	d	59	a	60	b
61	d	62	b	63	d	64	c	65	d	66	c	67	a	68	c	69	b	70	a
71	a	72	d	73	a	74	c	75	c	76	a	77	d	78	b	79	a	80	b
81	c	82	c	83	a	84	d	85	c	86	c	87	b	88	b	89	c	90	a
91	c	92	c	93	d	94	d	95	b	96	c	97	d	98	b	99	b	100	d
101	a	102	d	103	c	104	b	105	d	106	a	107	d	108	c	109	c	110	d
111	c	112	d	113	c	114	b	115	b	116	b	117	d	118	c	119	c	120	d
121	c	122	b	123	b	124	c	125	b	126	c	127	c	128	d	129	c	130	c
131	d	132	d	133	c	134	b	135	a	136	c	137	b	138	b	139	a	140	b
141	c	142	b	143	c	144	c	145	d	146	c	147	c	148	c	149	b	150	c

Scoring table

Total questions	Total attempted	Total correct	Total wrong	Score	Time taken
150					



1. Refer to paragraph 1.
2. Refer to the last paragraph.
3. Refer to paragraph 2.
4. Refer to paragraph 6 (last line).
5. Refer to paragraph 3 (last line).
6. Refer to paragraph 6.
7. Refer to paragraph 5.
8. Refer to paragraph 5.
9. Refer to paragraph 5.
10. Refer to paragraph 5.
11. Refer to paragraph 1.
12. Refer to the last paragraph.
13. Refer to paragraph 2.
14. Read the last line of the passage.
15. Refer to paragraph 6.
16. Refer to paragraph 5.
17. The actions of the First Couple have not been compared in the passage.
18. Refer to paragraph 4.
19. Refer to paragraphs 3 and 4.
20. Refer to paragraph 6.
21. Refer to paragraph 1.
22. Refer to the last paragraph.
23. Refer to paragraph 2.
24. Refer to paragraph 10.
25. Refer to paragraph 4.
26. HLL was not among the most preferred brands.
27. Refer to paragraph 6.
28. The passage is about Lakme entering the services business.
29. Refer to paragraph 7.
30. Refer to paragraph 3.
31. Amass is to accumulate or gather together.
32. Discreet is to be tactful in speech or action, especially to avoid social disgrace or embarrassment.
33. Cortege is a funeral procession.
34. Forestall is to act in advance in order to prevent.
35. Colossal is of immense size, huge, gigantic.
36. Illicit is unlawful or forbidden.
37. Flawed is the opposite of perfect.
38. Jarring sounds are unpleasant.
39. To be in peril means you are in danger.
40. Teetotaler is person who abstains from alcoholic drink.
41. Iconic relates to an icon or image, while cynosure is a center of attraction or admiration.
42. Dissecting an issue means to analyse, criticize or examine in detail.
43. Heritage is anything that is inherited such as the traditions and culture of country.
44. Premium products are high quality, expensive products.
45. Braid is used for edging or trimming of clothes, curtains etc.
46. 'Stepping up efforts' is the right answer.
47. Only (d) is appropriate.
48. Choice (b) is appropriate as it has the 'that - clause' and the definite article 'the' before 'selfish ... inside.'
49. Choice (b) has 'by' after 'than' and thus provides for parallelism.
50. Choice (a) has "you're feeling," and "the professionals urge," which are the correct expressions to use.
51. Nemesis is about punishment just as rationality is about logic.
52. Hack is to cut or chop roughly, while carve is to cut to produce a shape figure or pattern. Gouge and engrave are also related in a similar way.
53. Slur is unclear or garbled speech and smudge is blurred or smeared writing.
54. Prairies are present in North America and you find chateaux in France.
55. Hindsight is when you reflect after the event has occurred. Premonition is something you feel beforehand.
56. Avowed comes from 'vow'.
57. Stroll has to 'l's
58. Pandemonium comes form PAN + DEMON



59. Tattoos has two consecutive 'ts' and two 'o's
60. Predecessors comes from "to precede".
61. Since Dynamic Lajwanti stuffs 45 envelopes in 1.5 min,
she stuffs $\frac{45}{1.5} = 30$ envelopes in 1 min.
Now working together both of them stuff $45 + 30 = 75$ envelopes in 1 min.
 \therefore 300 envelopes will be stuffed in $\frac{300}{75} = 4$ min.
62. In the morning-noon session, he sells 0.4p. So he is left with $p - 0.4p = 0.6p$. He sells 60% of it in the afternoon session, i.e. $0.6p \times 0.6 = 0.36p$.
Now, had he sold twice of $0.36p$ i.e. $0.72p$, he would have to borrow 12 papers extra.
 $\therefore p + 12 = 0.4p + 0.72p$
 $\Rightarrow 12 = 1.12p - p = 0.12p$
 $\Rightarrow p = 100$
63. $a\%$ of $b = c \Rightarrow ab = 100c \dots (i)$
 $b\%$ of $c = a \Rightarrow bc = 100a \dots (ii)$
and $c\%$ of $a = 1 \Rightarrow ca = 100 \dots (iii)$
Multiplying (i), (ii) and (iii), $a^2b^2c^2 = 100^3 ac$
 $\Rightarrow ab^2c = 100^3 \dots (iv)$
Dividing (iv) by (iii), $\frac{ab^2c}{ac} = \frac{100^3}{100} \Rightarrow b = 100$
Now from (i), $100a = 100c \Rightarrow a = c \dots (v)$
Again from (iii) and (v), $a^2 = 100$
 $\Rightarrow a = c = 10$
Hence, only answer choice (d) is not true.
64. Among the given answer choices, only 208 meets the requirement. When 3 is subtracted from it, we get 205, which is not a multiple of 3.
65. We know
 $SI = \frac{PRT}{100}$, where R is rate of interest per annum, T is the number of time periods. Now R for half-year = 10% and $T = 1$.
 $\therefore SI = \frac{P \times 10 \times 1}{100} = 0.1P$
Thus, effective half-yearly interest rate is 10%.
66. As they are in AP,
 $\log_{10} b - \log_{10} a = \log_{10} c - \log_{10} b$
 $\Rightarrow 2 \log b = \log a + \log c$
 $\Rightarrow \log b^2 = \log ac$
 $\Rightarrow b^2 = ac$ [Removing logarithm form both sides]
 $\Rightarrow \frac{b}{a} = \frac{c}{b}$
 $\Rightarrow a, b, c$ are in GP

67. $\frac{\log_r q}{\log_r p} = \frac{3}{2}$ [Applying the logarithmic formula in which the base loses its relevance]
 $\Rightarrow \log_r q = \frac{3}{2}$
68. Let's assume that Pratima joined x months after the start. So while Rashmi has invested for 12 months, Pratima invests for $(12 - x)$ months.
Hence, $\frac{4500 \times 12}{3000 \times (12 - x)} = \frac{2}{1}$
 $\Rightarrow 3000x = 9000 \Rightarrow x = 3$
69. 5% of 800 = 40 of 25-paisa denomination coins were removed and 25% of 1200 = 300 of 50-paisa denomination coins were removed.
So the value of money removed = $(40 \times 25\text{-paisa}) + (300 \times 50\text{-paisa})$
= Rs. 10 + Rs. 150 = Rs. 160
Original value of money = $(800 \times 25 P) + (1200 \times 50 P)$
= Rs. 200 + Rs. 600 = Rs. 800
 \therefore Percentage of money removed = $\frac{160}{800} = \frac{1}{5} = 20\%$.
70. In one unit of X, there are 2 units of material B. So in 25 units of X, there would be 50 units of B. Similarly, in 25 units of Y, there would be 125 units of B.
 \therefore Total requirement of material B = $50 + 125 = 175$.
71. First 1,000 copies cost Rs. 10,000. So Rs. 62,300 is the cost for the rest 7,000 copies.
Now $7000x = 62300$
 $\Rightarrow x = \frac{62300}{7000} = \text{Rs. } 8.90$
72. In one sequence Princy receives a net amount of Rs. $20 - 15 = \text{Rs. } 5$.
In 8 sequences, she will get Rs. 40.
On the 9th sequence, she gets Rs. 20 by smiling and reaches the desired figure of 60 for the first time.
73. Since $(x + 1)$ and $(x + 2)$ are factors of the polynomial, if we put $x = -1$ and $x = -2$ in the expression, the value would come to be zero.
Hence, if $P(x) = x^3 + ax^2 - bx + 10$, then
 $P(-1) = 0 = -1 + a + b + 10$
 $\Rightarrow a + b = -9 \dots (i)$
and $P(-2) = 0 = -8 + 4a + 2b + 10$
 $\Rightarrow 2a + b = -1 \dots (ii)$
Now solving (i) and (ii), $a = 8$ and $b = -17$.



74.

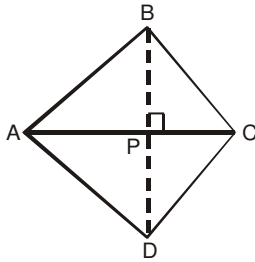

$$\begin{aligned} \text{Area of } ABCD &= 2 \times \text{Area of } \triangle ABC \\ &= 2\sqrt{9 \times 2 \times 3 \times 4} \\ &= 12\sqrt{6} \text{ m}^2 \end{aligned}$$

[Using Hero's formula, $\Delta = \sqrt{s(s-a)(s-b)(s-c)}$]

Since $\triangle ABC$ and $\triangle ACD$ are concurrent,

$$\triangle ABC = \frac{1}{2} \times ABCD = 6\sqrt{6} \text{ cm}^2$$

$$\triangle ABC = 6\sqrt{6} = \frac{1}{2} AC \times BP \text{ [if } BP \perp AC]$$

$$\Rightarrow \frac{1}{2} \times 6 \times BP = 6\sqrt{6}$$

$$\Rightarrow BP = 2\sqrt{6}$$

Similarly, we can find that DP [if $DP \perp AC$] = $2\sqrt{6}$

$$\therefore BD = BP + DP = 2\sqrt{6} + 2\sqrt{6} = 4\sqrt{6} \text{ m}$$

75. The readings give rise to the following diagram

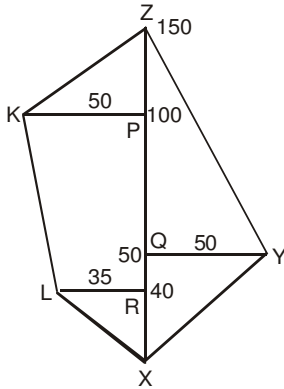

$$\text{Total area } \triangle XQY + \triangle QZY + \triangle KZP + \text{Trapezium KPRL} + \triangle XLR = 8250 \text{ m}^2$$

76. The ratio of their daily wages is $\frac{1}{2} : \frac{1}{3} : \frac{1}{5}$.

So the ratio of their wages for the full work is

$$\frac{10}{2} : \frac{12}{3} : \frac{15}{5}, \text{ i.e. } 5 : 4 : 3.$$

$$\text{Hence, A's amount} = \frac{5}{12} \times 144 = \text{Rs. } 60.$$

77. Since the given number is 299, the nearest perfect square below this number is $17^2 = 289$. The next perfect square would be $18^2 = 324$.
Therefore, the number to be added = $324 - 299 = 25$.

78. $\text{LCM}(10, 15, 25) = 150$; we have to find the nearest multiple of 150 that is a perfect square. Hence, the nearest such number is 900 which is six times of 150. 900 is also the square of 30.

79. Speed of the car is twice the speed of the auto. So time taken by the car is half the time taken by the auto. Ammar goes by car for 10 min and by auto for 30 min. Total time taken by him if he goes all the way by car

$$= 10 + \frac{1}{2}(30) = 10 + 15 = 25 \text{ min}$$

80.

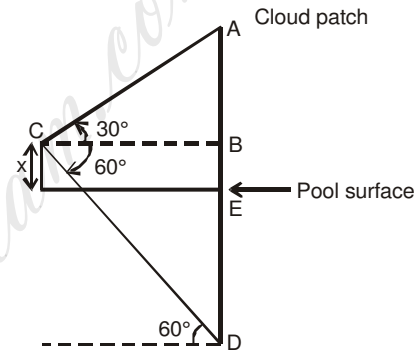

$$BC = \frac{AB}{\tan 30^\circ} \text{ [in } \triangle ABC]$$

$$\Rightarrow BC = \sqrt{3} AB$$

$$\text{Also } BC = \frac{BD}{\tan 60^\circ} \text{ [in } \triangle BDC]$$

$$\Rightarrow BC = \frac{BD}{\sqrt{3}}$$

$$\therefore \sqrt{3} AB = \frac{BD}{\sqrt{3}} = \frac{BE + ED}{\sqrt{3}}$$

$$\Rightarrow \sqrt{3} AB = \frac{x + ED}{\sqrt{3}}$$

$$\Rightarrow 3AB = x + ED$$

As $AE = ED$ [Both being reflections across the pool surface]

$$3AB = x + AE = x + AB + x \Rightarrow x = AB$$

$$\text{Therefore, height of the cloud patch} = AB + BE = x + x = 2x.$$



$$\frac{1}{y} \frac{dy}{dx} = \frac{1}{2} \log x \frac{dy}{dx} + \frac{1}{2} y \frac{1}{x}$$

$$\Rightarrow \left(\frac{1}{y} - \frac{1}{2} \log x \right) \frac{dy}{dx} = \frac{1}{2} \frac{y}{x}$$

$$\Rightarrow \frac{dy}{dx} = \frac{1}{2} \frac{y}{x} \left(\frac{2y}{2-y \log x} \right)$$

$$= \frac{y^2}{x(2-y \log x)}$$

90. We know that

$$\lim_{x \rightarrow 0} \frac{\tan x}{x} = 1 \text{ and } \lim_{x \rightarrow 0} \frac{\sin x}{x} = 1$$

$$\therefore \lim_{x \rightarrow 0} \frac{\tan x + \sin x}{x} = \lim_{x \rightarrow 0} \frac{\tan x}{x} + \lim_{x \rightarrow 0} \frac{\sin x}{x}$$

$$= 1 + 1 = 2$$

91. Using the L'Hospital's rule

$$-2 = \lim_{x \rightarrow c} \frac{c^x \log_e c - 2c x^{c-1}}{x^x + x^x \log_e x}$$

$$\Rightarrow -2 = \frac{c^c \log_e c - 2c^c}{c^c + c^c \log_e c}$$

$$\Rightarrow -2 = \frac{\log_e c - 2}{1 + \log_e c}$$

$$\Rightarrow -2 - 2 \log_e c = \log_e c - 2$$

$$\Rightarrow \log_e c = 0$$

$$\Rightarrow c = 1$$

92. We have

$$17 = \frac{2+x+5+x+6+x+8+x+9+x+11+x+12+x+14+x+15+24}{10}$$

$$\Rightarrow 170 = 8x + 106$$

$$\Rightarrow 8x = 64$$

$$\Rightarrow x = 8$$

93. We have $y = \log[\sin^{-1}(\sqrt{x})]$
Differentiating w.r.t. x, we get

$$\frac{dy}{dx} = \frac{1}{\sin^{-1}(\sqrt{x})} \cdot \frac{1}{\sqrt{1-x}} \cdot \frac{1}{2} \cdot \frac{1}{\sqrt{x}}$$

94. Assume one root of the quadratic equation be α . Then the other root is α^4 .

$$\therefore \alpha + \alpha^4 = -\frac{q}{p} \quad \dots (i)$$

$$\text{and } \alpha \cdot \alpha^4 = \frac{r}{p}$$

$$\Rightarrow \alpha = \left(\frac{r}{p} \right)^{\frac{1}{5}} \quad \dots (ii)$$

Substituting the value of α from (ii) in (i), we get

$$\left(\frac{r}{p} \right)^{\frac{1}{5}} + \left(\frac{r}{p} \right)^{\frac{4}{5}} = -\frac{q}{p}$$

$$\Rightarrow p \left(\frac{r}{p} \right)^{\frac{1}{5}} + p \left(\frac{r}{p} \right)^{\frac{4}{5}} = -q$$

$$\Rightarrow p^{1-\frac{1}{5}} \cdot r^{\frac{1}{5}} + p^{1-\frac{4}{5}} r^{\frac{4}{5}} - q = 0$$

$$\Rightarrow p^{\frac{4}{5}} r^{\frac{1}{5}} + p^{\frac{1}{5}} r^{\frac{4}{5}} + q = 0$$

95. When P and N are together, taking both as one letter, we have 5 letters, and P and N can be arranged in 2! ways. Hence, total number of words = $5! \times 2!$
= $5 \times 4 \times 3 \times 2 \times 1 \times 2 = 240$.

96.

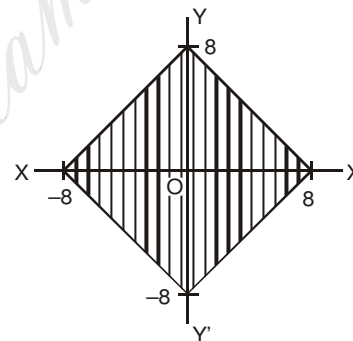

We have $|x| + |y| = 8$,
when $y = 0$, $x = 8$ or -8
and when $x = 0$, $y = 8$ or -8 .

$$\text{Area} = 4 \times \frac{1}{2} \times 8 \times 8 = 128 \text{ sq.unit.}$$

97. There are only two possibilities:
either black ball goes in green or yellow jar.

$$\text{Hence, probability} = \frac{1}{2}.$$

Alternative method:

In yellow jar, 9 red balls and 1 black ball can be chosen by ${}^{19}C_9 \times {}^1C_1$ ways.

$$\text{In yellow jar, total number of ways} = {}^{20}C_9$$



$$\text{Probability} = \frac{{}^{19}C_9}{{}^{20}C_9} = \frac{19!}{20!} \cdot \frac{9!}{10!} = \frac{10}{20} = \frac{1}{2}$$

98. Average dividend amount = $\frac{68.59}{2509} = \text{Rs. } 2734$
99. In TIGF scheme, average redemption amount per warrant = $\text{Rs. } \frac{83,000}{7} = \text{Rs. } 11857.14$
- In FIBF scheme, average = $\text{Rs. } \frac{13,000}{1} = \text{Rs. } 13,000$
- Ratio = $11857.14 : 13000 = 91 : 100 \approx 9 : 10$
100. (I) TIGF and TIIF = $\text{Rs. } (3.26 + 42.18 + 0.83 + 2.30)$ lakh = $\text{Rs. } 48.57$ lakh
 (II) Total number of warrants in TIIF scheme = $1601 + 48 = 1649$ out of total 2578 claims.
 Hence, it is more than 60%.
101. Required percentage = $\frac{5.39}{68.59} \approx 7.8\%$
102. The data on unclaimed dividend amounts for FIIF, FIBF and FIGF are not given.
103. Both the statements combined gives unique solution of x and y.
104. From (I), we get that the point (x, y) is on a circle whose centre is at the origin and radius is 4.
 From (II) again, the distance from origin is 4.
105. Statement (I) does not give any unique value of x, y, or z. Statement (II) does not give any unique value. Combining the two, we only get at least two of them are zero. So both statements together are not sufficient.
106. From (I), we can form a linear equation to solve for the value of k. So (I) is sufficient. From (II), we do not get any unique value.
107. Both the statements independently are insufficient. Also combining the two, we do not get any value.

Questions 108 to 112:

Go through the choices and the diagram.

Questions 113 to 117:

On the basis of the given information, we get Alto in the middle



Fiat is ranked three places less than Givo would mean that Fiat and Givo cannot be at the extreme positions. The two possibilities left are

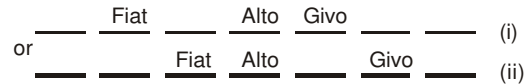

Now the possibility that Benz is as much less than Alto as Cadillac is greater than Fiat in ranking can be justified in only this arrangement and in none else, keeping all other restrictions in mind.



Now using the condition that Electra is ranked higher than Benz, we get the final arrangement as:

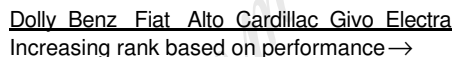

And on the basis of the above arrangement, rest of the questions can be solved very easily.

Questions 118 to 120:

- From (I), we get
 Vikram Chandra × Harper Collins.
- From (II), we get
 Fiction × Harper Collins or Oxford University Press.
- From (III), we get
 V. S. Naipaul and Vikaram Seth × Non-fiction work.
- From (II), we get
 Fiction – Penguin ... (A)
- From (I), we get
 Vikram Chandra – either Oxford or Penguin ... (B)
- From (III), we get
 Vikram Chandra – Non-fiction ... (C)
- Combining (A), (B) and (C), we get
 Vikram Chandra – Non-Fiction – Oxford University Press ... (D)
- and
 using (IV), we get
 V. S. Naipaul – Poetry ... (E)
- We already have Fiction – Penguin ... (A)
- Using (D), (E) and (A), we get
 Vikram Chandra – Non-fiction – Oxford University Press
 V. S. Naipaul – Poetry – Harper Collins
 Vikram Seth – Fiction – Penguin

And on the basis of the above arrangement, rest of the questions can be solved very easily.

