

CH : CHEMICAL ENGINEERING

Duration: Three Hours

Maximum Marks: 100

Read the following instructions carefully.

1. Do not open the seal of the Question Booklet until you are asked to do so by the invigilator.
2. Take out the **Optical Response Sheet (ORS)** from this Question Booklet **without breaking the seal** and read the instructions printed on the ORS carefully.
3. On the right half of the **ORS**, using **ONLY a black ink ball point pen**, (i) darken the bubble corresponding to your test paper code and the appropriate bubble under each digit of your registration number and (ii) write your registration number, your name and name of the examination centre and put your signature at the specified location.
4. This Question Booklet contains **20** pages including blank pages for rough work. After you are permitted to open the seal, please check all pages and report discrepancies, if any, to the invigilator.
5. There are a total of 65 questions carrying 100 marks. All these questions are of objective type. Each question has only **one** correct answer. Questions must be answered on the left hand side of the **ORS** by darkening the appropriate bubble (marked A, B, C, D) using **ONLY a black ink ball point pen** against the question number. **For each question darken the bubble of the correct answer.** More than one answer bubbled against a question will be treated as an incorrect response.
6. Since bubbles darkened by the black ink ball point pen **cannot** be erased, candidates should darken the bubbles in the ORS **very carefully**.
7. Questions Q.1 – Q.25 carry 1 mark each. Questions Q.26 – Q.55 carry 2 marks each. The 2 marks questions include two pairs of common data questions and two pairs of linked answer questions. The answer to the second question of the linked answer questions depends on the answer to the first question of the pair. If the first question in the linked pair is wrongly answered or is unattempted, then the answer to the second question in the pair will not be evaluated.
8. Questions Q.56 – Q.65 belong to General Aptitude (GA) section and carry a total of 15 marks. Questions Q.56 – Q.60 carry 1 mark each, and questions Q.61 – Q.65 carry 2 marks each.
9. Unattempted questions will result in zero mark and wrong answers will result in **NEGATIVE** marks. For all 1 mark questions, $\frac{1}{3}$ mark will be deducted for each wrong answer. For all 2 marks questions, $\frac{2}{3}$ mark will be deducted for each wrong answer. However, in the case of the linked answer question pair, there will be negative marks only for wrong answer to the first question and no negative marks for wrong answer to the second question.
10. Calculator is allowed whereas charts, graph sheets or tables are **NOT** allowed in the examination hall.
11. Rough work can be done on the question paper itself. Blank pages are provided at the end of the question paper for rough work.
12. Before the start of the examination, write your name and registration number in the space provided below using a black ink ball point pen.

Name							
Registration Number	CH						

Q. 1 – Q. 25 carry one mark each.

Q.1 Consider the following set of linear algebraic equations

$$x_1 + 2x_2 + 3x_3 = 2$$

$$x_2 + x_3 = -1$$

$$2x_2 + 2x_3 = 0$$

The system has

- (A) a unique solution (B) no solution
(C) an infinite number of solutions (D) only the trivial solution

Q.2 If a and b are arbitrary constants, then the solution to the ordinary differential equation

$$\frac{d^2y}{dx^2} - 4y = 0$$

is

- (A) $y = ax + b$
(B) $y = ae^{-x}$
(C) $y = a \sin 2x + b \cos 2x$
(D) $y = a \cosh 2x + b \sinh 2x$

Q.3 For the function $f(t) = e^{-t/\tau}$, the Taylor series approximation for $t \ll \tau$ is

- (A) $1 + \frac{t}{\tau}$ (B) $1 - \frac{t}{\tau}$ (C) $1 - \frac{t^2}{2\tau^2}$ (D) $1 + t$

Q.4 A box containing 10 identical compartments has 6 red balls and 2 blue balls. If each compartment can hold only one ball, then the number of different possible arrangements are

- (A) 1026 (B) 1062 (C) 1260 (D) 1620

Q.5 Consider the following (2×2) matrix

$$\begin{pmatrix} 4 & 0 \\ 0 & 4 \end{pmatrix}$$

Which one of the following vectors is NOT a valid eigenvector of the above matrix ?

- (A) $\begin{pmatrix} 1 \\ 0 \end{pmatrix}$ (B) $\begin{pmatrix} -2 \\ 1 \end{pmatrix}$ (C) $\begin{pmatrix} 4 \\ -3 \end{pmatrix}$ (D) $\begin{pmatrix} 0 \\ 0 \end{pmatrix}$

Q.6 In a throttling process, the pressure of an ideal gas reduces by 50 %. If C_p and C_v are the heat capacities at constant pressure and constant volume, respectively ($\gamma = C_p/C_v$), the specific volume will change by a factor of

- (A) 2 (B) $2^{1/\gamma}$ (C) $2^{(\gamma-1)/\gamma}$ (D) 0.5

- Q.7 If the temperature of saturated water is increased infinitesimally at constant entropy, the resulting state of water will be
- (A) Liquid (B) Liquid – vapor coexistence
(C) Saturated vapor (D) Solid
- Q.8 In a parallel flow heat exchanger operating under steady state, hot liquid enters at a temperature $T_{h,in}$ and leaves at a temperature $T_{h,out}$. Cold liquid enters at a temperature $T_{c,in}$ and leaves at a temperature $T_{c,out}$. Neglect any heat loss from the heat exchanger to the surrounding. If $T_{h,in} \gg T_{c,in}$, then for a given time interval, which ONE of the following statements is true?
- (A) Entropy gained by the cold stream is GREATER than entropy lost by the hot stream
(B) Entropy gained by the cold stream is EQUAL to the entropy lost by the hot stream
(C) Entropy gained by the cold stream is LESS than the entropy lost by the hot stream
(D) Entropy gained by the cold stream is ZERO
- Q.9 For an exothermic reversible reaction, which one of the following correctly describes the dependence of the equilibrium constant (K) with temperature (T) and pressure (P) ?
- (A) K is independent of T and P
(B) K increases with an increase in T and P
(C) K increases with T and decreases with P
(D) K decreases with an increase in T and is independent of P
- Q.10 Water is flowing under laminar conditions in a pipe of length L . If the diameter of the pipe is doubled, for a constant volumetric flow rate, the pressure drop across the pipe
- (A) decreases 2 times (B) decreases 16 times
(C) increases 2 times (D) increases 16 times
- Q.11 The local velocity of a fluid along a streamline can be measured by
- (A) Pitot tube (B) Venturi meter (C) Rotameter (D) Orifice meter
- Q.12 For uniform laminar flow (in the x -direction) past a flat plate at high Reynolds number, the local boundary layer thickness (δ) varies with the distance along the plate (x) as
- (A) $\delta \propto x^{1/4}$ (B) $\delta \propto x^{1/3}$ (C) $\delta \propto x^{1/2}$ (D) $\delta \propto x$
- Q.13 In a mixing tank operating at very high Reynolds number ($> 10^4$), if the diameter of the impeller is doubled (other conditions remaining constant), the power required increases by a factor of
- (A) 1/32 (B) 1/4 (C) 4 (D) 32
- Q.14 For heat transfer across a solid-fluid interface, which one of the following statements is **NOT** true when the Biot number is very small compared to 1?
- (A) Conduction resistance in the solid is very small compared to convection resistance in the fluid
(B) Temperature profile within the solid is nearly uniform
(C) Temperature drop in the fluid is significant
(D) Temperature drop in the solid is significant

- Q.15 A solid sphere with an initial temperature T_i is immersed in a large thermal reservoir of temperature T_o . The sphere reaches a steady temperature after a certain time t_1 . If the radius of the sphere is doubled, the time required to reach steady-state will be
- (A) $t_1/4$ (B) $t_1/2$ (C) $2t_1$ (D) $4t_1$
- Q.16 If the Nusselt number (Nu) for heat transfer in a pipe varies with Reynolds number (Re) as $Nu \propto Re^{0.8}$, then for constant average velocity in the pipe, the heat transfer coefficient varies with the pipe diameter D as
- (A) $D^{-1.8}$ (B) $D^{-0.2}$ (C) $D^{0.2}$ (D) $D^{1.8}$
- Q.17 In the McCabe-Thiele diagram, if the x-coordinate of the point of intersection of the q-line and the vapor-liquid equilibrium curve is greater than the x-coordinate of the feed point, then the quality of the feed is
- (A) super-heated vapor (B) liquid below bubble point
(C) saturated vapor (D) saturated liquid
- Q.18 For which of the following combinations, does the absorption operation become gas-film controlled?
- P. The solubility of gas in the liquid is very high
Q. The solubility of gas in the liquid is very low
R. The liquid-side mass transfer coefficient is much higher than the gas-side mass transfer coefficient
S. The liquid-side mass transfer coefficient is much lower than the gas-side mass transfer coefficient
- (A) P & Q (B) P & R (C) P & S (D) Q & R
- Q.19 The half-life of an n^{th} order reaction in a batch reactor depends on
- (A) only the rate constant
(B) only the rate constant and the order of the reaction
(C) only the rate constant and the initial reactant concentration
(D) the rate constant, initial reactant concentration, and the order of the reaction
- Q.20 Consider the reaction scheme shown below

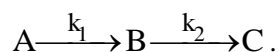

Both the reactions are first-order. The activation energies for k_1 and k_2 are 80 and 20 kJ/mol, respectively. To maximize the yield of B, it is preferable to use

- (A) CSTR and high temperature
(B) PFR and high temperature
(C) CSTR and low temperature
(D) PFR and low temperature

- Q.21 In petroleum refining, catalytic reforming is used to convert
- (A) Paraffins and naphthenes to aromatics (B) Paraffins to hydrogen and carbon monoxide
- (C) Gas oil to diesel and gasoline (D) Light olefins to gasoline
- Q.22 The final boiling points of gasoline, diesel, atmospheric gas oil (AGO) and lubricating oils vary as
- (A) gasoline > diesel > AGO > lubricating oils
- (B) lubricating oils > AGO > diesel > gasoline
- (C) AGO > lubricating oils > diesel > gasoline
- (D) lubricating oils > diesel > AGO > gasoline
- Q.23 The main unit processes used for the production of hydrogen from natural gas are steam reforming (SR), pressure swing adsorption (PSA), low temperature water gas shift reaction (LT WGS) and high temperature water gas shift reaction (HT WGS). The correct sequence of these in the plant is
- (A) SR; LT WGS; HT WGS; PSA
- (B) PSA; SR; LT WGS; HT WGS
- (C) SR; HT WGS; LT WGS; PSA
- (D) PSA; HT WGS; LT WGS; SR
- Q.24 A thermometer initially at 100°C is dipped at $t = 0$ into an oil bath, maintained at 150°C. If the recorded temperature is 130°C after 1 minute, then the time constant of thermometer (in min) is
- (A) 1.98 (B) 1.35 (C) 1.26 (D) 1.09
- Q.25 The Bode stability criterion is applicable when
- (A) Gain and phase curves decrease continuously with frequency
- (B) Gain curve increases and phase curve decreases with frequency
- (C) Gain curve and phase curve both increase with frequency
- (D) Gain curve decreases and phase curve increases with frequency

Q. 26 to Q. 55 carry two marks each.

- Q.26 The one - dimensional unsteady state heat conduction equation in a hollow cylinder with a constant heat source q is

$$\frac{\partial T}{\partial t} = \frac{1}{r} \frac{\partial}{\partial r} \left(r \frac{\partial T}{\partial r} \right) + q$$

If A and B are arbitrary constants, then the steady state solution to the above equation is

- (A) $T(r) = -\frac{qr^2}{2} + \frac{A}{r} + B$
 (B) $T(r) = -\frac{qr^2}{4} + A \ln r + B$
 (C) $T(r) = A \ln r + B$
 (D) $T(r) = \frac{qr^2}{4} + A \ln r + B$
- Q.27 If a is a constant, then the value of the integral $a^2 \int_0^{\infty} x e^{-ax} dx$ is

- (A) $1/a$ (B) a (C) 1 (D) 0

- Q.28 The Newton – Raphson method is used to find the roots of the equation

$$f(x) = x - \cos \pi x \quad 0 \leq x \leq 1.$$

If the initial guess for the root is 0.5, then the value of x after the first iteration is

- (A) 1.02 (B) 0.62 (C) 0.55 (D) 0.38

- Q.29 If $i = \sqrt{-1}$, the value of the integral

$$\oint_c \frac{7z+i}{z(z^2+1)} dz \quad |z| < 2,$$

using the Cauchy residue theorem is

- (A) $2\pi i$ (B) 0 (C) -6π (D) 6π

- Q.30 An insulated, evacuated container is connected to a supply line of an ideal gas at pressure P_s , temperature T_s and specific volume v_s . The container is filled with the gas until the pressure in the container reaches P_s . There is no heat transfer between the supply line to the container, and kinetic and potential energies are negligible. If C_p and C_v are the heat capacities at constant pressure and constant volume, respectively ($\gamma = C_p/C_v$), then the final temperature of the gas in the container is

- (A) γT_s (B) T_s (C) $(\gamma - 1)T_s$ (D) $(\gamma - 1)T_s/\gamma$

- Q.31 Consider a binary liquid mixture at constant temperature T and pressure P . If the enthalpy change of mixing, $\Delta H = 5x_1x_2$, where x_1 and x_2 are the mole fraction of species 1 and 2 respectively, and the entropy change of mixing $\Delta S = -R[x_1 \ln x_1 + x_2 \ln x_2]$ (with $R = 8.314 \text{ J/mol.K}$), then the minimum value of the Gibbs free energy change of mixing at 300 K occurs when
- (A) $x_1 = 0$ (B) $x_1 = 0.2$ (C) $x_1 = 0.4$ (D) $x_1 = 0.5$
- Q.32 A bed of spherical glass beads (density 3000 kg/m^3 , diameter 1 mm, bed porosity 0.5) is to be fluidized by a liquid of density 1000 kg/m^3 and viscosity 0.1 Pa.s . Assume that the Reynolds number based on particle diameter is very small compared to one. If $g = 10 \text{ m/s}^2$, then the minimum velocity (in m/s) required to fluidize the bed is
- (A) 3.33×10^{-4} (B) 3.33×10^{-1} (C) 3 (D) 30
- Q.33 For the enclosure formed between two concentric spheres as shown below ($R_2 = 2R_1$), the fraction of radiation leaving the surface area A_2 that strikes itself is

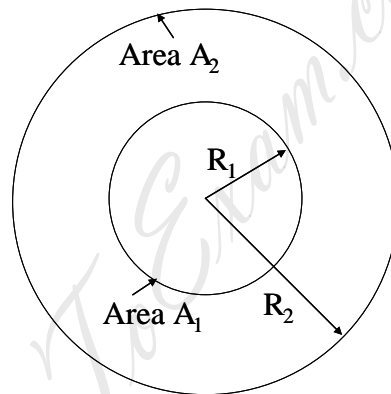

- (A) 1/4 (B) 1/2 (C) $1/\sqrt{2}$ (D) 3/4
- Q.34 Heat is generated at a steady rate of 100 W due to resistance heating in a long wire (length = 5 m, diameter = 2 mm). This wire is wrapped with an insulation of thickness 1 mm that has a thermal conductivity of 0.1 W/m.K . The insulated wire is exposed to air at 30°C . The convective heat transfer between the wire and surrounding air is characterized by a heat transfer coefficient of $10 \text{ W/m}^2.\text{K}$. The temperature (in $^\circ\text{C}$) at the interface between the wire and the insulation is
- (A) 211.2 (B) 242.1 (C) 311.2 (D) 484.2
- Q.35 In a counter-flow double pipe heat exchanger, oil ($\dot{m} = 2 \text{ kg/s}$, $C_p = 2.1 \text{ kJ/kg.}^\circ\text{C}$) is cooled from 90°C to 40°C by water ($\dot{m} = 1 \text{ kg/s}$, $C_p = 4.2 \text{ kJ/kg.}^\circ\text{C}$) which enters the inner tube at 10°C . The radius of the inner tube is 3 cm and its length is 5 m. Neglecting the wall resistance, the overall heat transfer coefficient based on the inner radius, in $\text{kW/m}^2.\text{K}$, is
- (A) 0.743 (B) 7.43 (C) 74.3 (D) 2475

Q.36 The rate-controlling step for the solid-catalyzed irreversible reaction

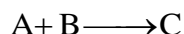

is known to be the reaction of adsorbed A with adsorbed B to give adsorbed C. If P_i is the partial pressure of component i and K_i is the adsorption equilibrium constant of component i, then the form of the Langmuir-Hinshelwood rate expression will be

- (A) $\text{rate} \propto \frac{P_A P_B}{1 + K_A P_A + K_B P_B + K_C P_C}$
- (B) $\text{rate} \propto \frac{P_A P_B}{(1 + K_A P_A + K_B P_B + K_C P_C)^2}$
- (C) $\text{rate} \propto \frac{P_A P_B}{(1 + K_A P_A + K_B P_B + K_C P_C)^{0.5}}$
- (D) $\text{rate} \propto \frac{P_A P_B}{P_C}$

Q.37 Consider the drying operation shown in the figure below for a solid loading (dry basis) of 50 kg/m^2 with a constant drying rate of $5 \text{ kg/m}^2 \cdot \text{h}$. The falling rate of drying is linear with moisture content.

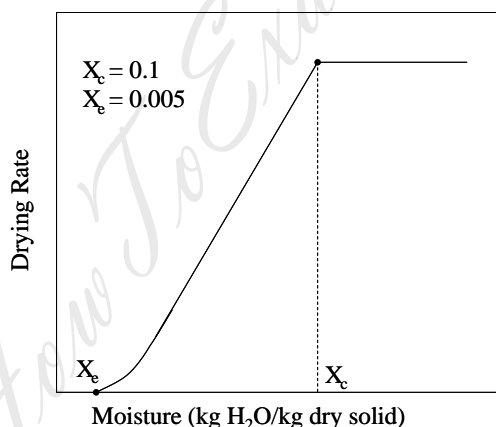

The drying time (in hrs) required to reduce an initial moisture content of 25% to a final moisture content of 2% is

- (A) 1.55 (B) 1.75 (C) 3.25 (D) 4.55
- Q.38 An equimolar mixture of A and B (A being more volatile) is flash distilled continuously at a feed rate of 100 kmol/h , such that the liquid product contains 40 mol % of A. If the relative volatility is 6, then the vapor product, in kmol/h , is
- (A) 10 (B) 20 (C) 25 (D) 45
- Q.39 A thermocouple having a linear relationship between 0°C and 350°C shows an emf of zero and 30.5 mV , respectively at these two temperatures. If the cold junction temperature is shifted from 0°C to 30°C , then the emf correction (in mV) is
- (A) 3.13 (B) 2.92 (C) 2.61 (D) 2.02

Q.40 The characteristic equation for a system is

$$s^3 + 9s^2 + 26s + 12(2 + K_c) = 0.$$

Using the Routh test, the value of K_c that will keep the system on the verge of instability is

- (A) 20.9 (B) 18.4 (C) 17.5 (D) 15.3

Q.41 The elementary reversible exothermic gas-phase reaction

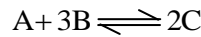

is to be conducted in a non-isothermal, non-adiabatic plug flow reactor. The maximum allowable reactor temperature is T_{max} . To minimize the total reactor volume, the variation of reactor temperature (T) with axial distance from the inlet (z) should be

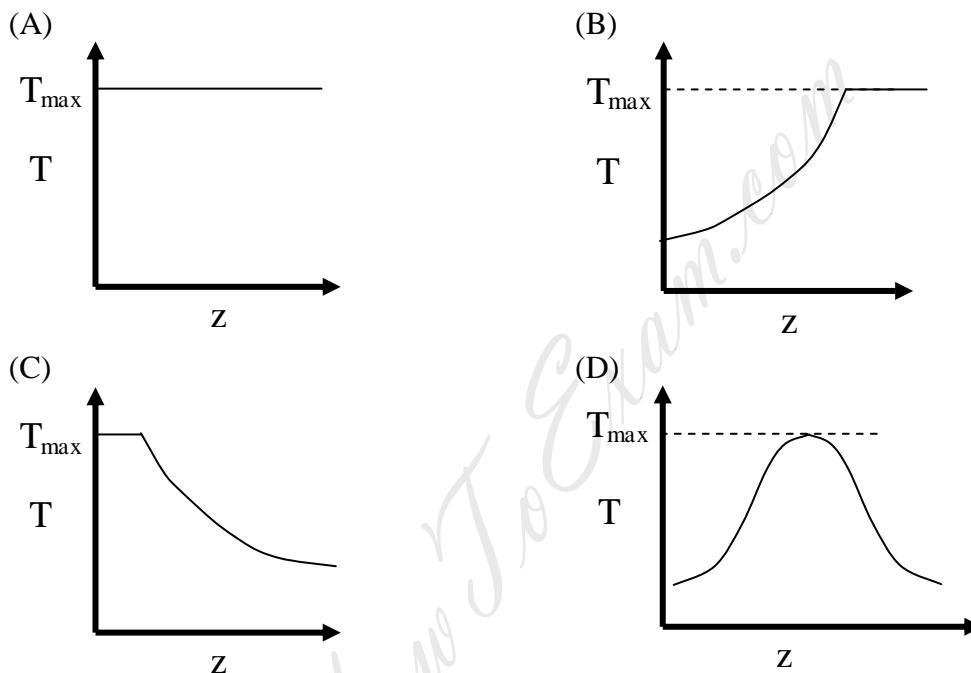

Q.42 The block diagram of a system with a proportional controller is shown below

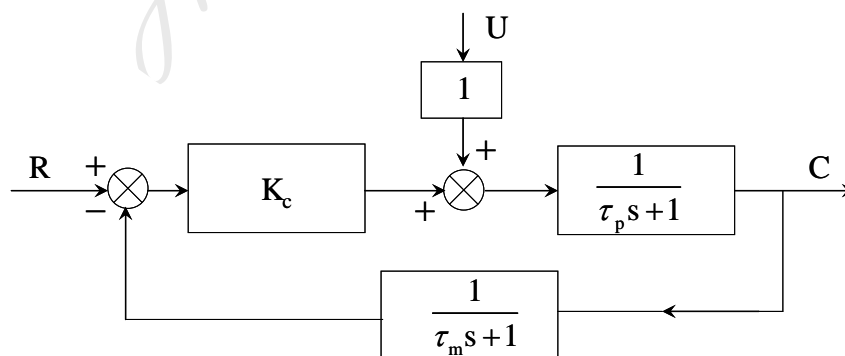

A unit step input is introduced in the set point. The value of K_c to provide a critically damped response for $U = 0$, $\tau_p = 8$ and $\tau_m = 1$ is

- (A) 3.34 (B) 2.58 (C) 1.53 (D) 1.12

- Q.43 A batch reactor produces 1×10^5 kg of a product per year. The total batch time (in hours) of the reactor is $k\sqrt{P_B}$, where P_B is the product per batch in kg and $k = 1.0 \text{ h}/\sqrt{\text{kg}}$. The operating cost of the reactor is Rs. 200/h. The total annual fixed charges are Rs. $340 \times P_B$ and the annual raw material cost is Rs. 2×10^6 . The optimum size (in kg) of each batch (adjusted to the nearest integer) is
- (A) 748 (B) 873 (C) 953 (D) 1148

- Q.44 Heat integration is planned in a process plant at an investment Rs. 2×10^6 . This would result in a net energy savings of 20 GJ per year. If the nominal rate of interest is 15% and the plant life is 3 years, then the breakeven cost of energy, in Rs. per GJ (adjusted to the nearest hundred), is
- (A) 33500 (B) 43800 (C) 54200 (D) 65400

- Q.45 In a 1-1 pass floating head type shell and tube heat exchanger, the tubes (od = 25 mm; id = 21 mm) are arranged in a square pitch. The tube pitch is 32 mm. The thermal conductivity of the shell side fluid is 0.19 W/m.K, and the Nusselt number is 200. The shell-side heat transfer coefficient (in $\text{W}/\text{m}^2\cdot\text{K}$), rounded off to the nearest integer, is
- (A) 1100 (B) 1400 (C) 1800 (D) 2100

- Q.46 Match the process in **Group I** with the catalyst in **Group II**

Group I	Group II
P. Fischer-Tropsch synthesis	I. Nickel
Q. Formaldehyde from methanol	II. Fe_2O_3
R. Hydrogenation of vegetable oils	III. Silver
S. Dehydrogenation of ethylbenzene	IV. Cobalt

(A) P-III, Q-IV, R-I, S-II (B) P-IV, Q-II, R-I, S-III
 (C) P-IV, Q-III, R-I, S-II (D) P-III, Q-IV, R-II, S-I

- Q.47 Match the polymer in **Group I** to the polymer characteristic in **Group II**

Group I	Group II
P. Polyethylene	I. Elastomer
Q. Phenol-formaldehyde polymer	II. Fiber
R. Polyisoprene	III. Thermoplastic
S. Polyester	IV. Thermosetting polymer

(A) P-III, Q-IV, R-I, S-II (B) P-IV, Q-II, R-III, S-I
 (C) P-III, Q-II, R-I, S-IV (D) P-IV, Q-III, R-I, S-II

Common Data Questions

Common Data for Questions 48 and 49:

A counter-current extraction column is designed to remove 99% of solute C from a solution of solvent A and solute C using pure solvent B. The initial concentration of solute in the solution of A + C is 20 wt %, and the total flow of solution is 1000 kg/h. If the equilibrium relationship is $Y = 2X$, where $Y = \text{mass of C/mass of A}$ and $X = \text{mass of C/mass of B}$.

Q.48 The minimum flow rate of solvent B required (in kg/h) is

- (A) 1454 (B) 1584 (C) 1676 (D) 1874

Q.49 If the flow rate of B is 2400 kg/h, then the theoretical number of stages in the column, using Kremser's equation (adjusted to the next integer) is

- (A) 5 (B) 9 (C) 11 (D) 13

Common Data for Questions 50 and 51:

The reaction $A_{(\text{liq})} + B_{(\text{gas})} \rightarrow C_{(\text{liq})} + D_{(\text{gas})}$, is carried out in a reactor followed by a separator as shown below

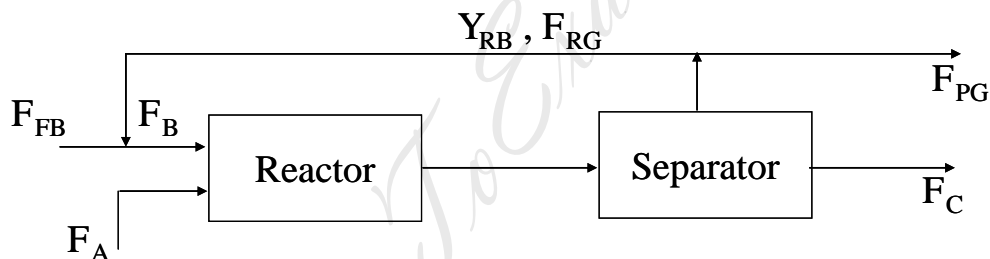

Notation:

Molar flow rate of fresh B is F_{FB}

Molar flow rate of A is F_{A}

Molar flow rate of recycle gas is F_{RG}

Mole fraction of B in recycle gas is Y_{RB}

Molar flow rate of purge gas is F_{PG}

Molar flow rate of C is F_{C}

Here, $F_{\text{FB}} = 2 \text{ mol/s}$; $F_{\text{A}} = 1 \text{ mol/s}$, $F_{\text{B}}/F_{\text{A}} = 5$ and A is completely converted.

Q.50 If $Y_{\text{RB}} = 0.3$, the ratio of recycle gas to purge gas ($F_{\text{RG}}/F_{\text{PG}}$) is

- (A) 2 (B) 5 (C) 7 (D) 10

Q.51 If the ratio of recycle gas to purge gas ($F_{\text{RG}}/F_{\text{PG}}$) is 4 then Y_{RB} is

- (A) 3/8 (B) 2/5 (C) 1/2 (D) 3/4

Linked Answer Questions

Statement for Linked Answer Questions 52 and 53:

A Newtonian fluid of viscosity μ flows between two parallel plates due to the motion of the bottom plate (as shown below), which is moved with a velocity V . The top plate is stationary.

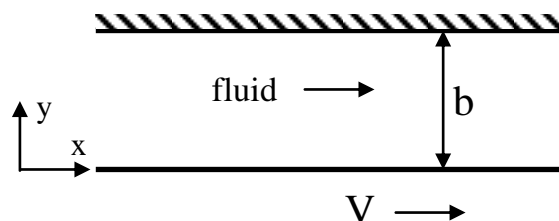

Q.52 The steady, laminar velocity profile in the x -direction is

(A) $V \left[\frac{y}{b} \right]$

(B) $V \left[\left(\frac{y}{b} \right)^2 - 1 \right]$

(C) $V \left[1 - \left(\frac{y}{b} \right)^2 \right]$

(D) $V \left[1 - \frac{y}{b} \right]$

Q.53 The force per unit area (in the x -direction) that must be exerted on the bottom plate to maintain the flow is

(A) $\mu V/b$

(B) $-\mu V/b$

(C) $2\mu V/b$

(D) $-2\mu V/b$

Statement for Linked Answer Questions 54 and 55:

The first order liquid phase reaction $A \rightarrow P$ is conducted isothermally in a plug flow reactor of 5 liter volume. The inlet volumetric flow rate is 1 liter/min and the inlet concentration of A is 2 mole/liter.

Q.54 If the exit concentration of A is 0.5 mole /liter, then the rate constant, in min^{-1} , is

(A) 0.06

(B) 0.28

(C) 0.42

(D) 0.64

Q.55 The plug flow reactor is replaced by 3 mixed flow reactors in series, each of 2.0 liters volume. The exact conversion of A (in %) is

(A) 35.9

(B) 52.5

(C) 73.7

(D) 94.8

General Aptitude (GA) Questions

Q. 56 – Q. 60 carry one mark each.

Q.56 Which one of the following options is the closest in meaning to the word given below?

Mitigate

- (A) Diminish (B) Divulge (C) Dedicate (D) Denote

Q.57 Choose the most appropriate alternative from the options given below to complete the following sentence:

Despite several _____ the mission succeeded in its attempt to resolve the conflict.

- (A) attempts (B) setbacks (C) meetings (D) delegations

Q.58 The cost function for a product in a firm is given by $5q^2$, where q is the amount of production. The firm can sell the product at a market price of ₹ 50 per unit. The number of units to be produced by the firm such that the profit is maximized is

- (A) 5 (B) 10 (C) 15 (D) 25

Q.59 Choose the most appropriate alternative from the options given below to complete the following sentence:

Suresh's dog is the one _____ was hurt in the stampede.

- (A) that (B) which (C) who (D) whom

Q.60 Choose the grammatically **INCORRECT** sentence:

- (A) They gave us the money back less the service charges of Three Hundred rupees.
 (B) This country's expenditure is not less than that of Bangladesh.
 (C) The committee initially asked for a funding of Fifty Lakh rupees, but later settled for a lesser sum.
 (D) This country's expenditure on educational reforms is very less.

Q. 61 - Q. 65 carry two marks each.

Q.61 An automobile plant contracted to buy shock absorbers from two suppliers X and Y. X supplies 60% and Y supplies 40% of the shock absorbers. All shock absorbers are subjected to a quality test. The ones that pass the quality test are considered reliable. Of X's shock absorbers, 96% are reliable. Of Y's shock absorbers, 72% are reliable.

The probability that a randomly chosen shock absorber, which is found to be reliable, is made by Y is

- (A) 0.288 (B) 0.334 (C) 0.667 (D) 0.720

Q.62 A political party orders an arch for the entrance to the ground in which the annual convention is being held. The profile of the arch follows the equation $y = 2x - 0.1x^2$ where y is the height of the arch in meters. The maximum possible height of the arch is

- (A) 8 meters (B) 10 meters (C) 12 meters (D) 14 meters

Q.63 Wanted Temporary, Part-time persons for the post of Field Interviewer to conduct personal interviews to collect and collate economic data. Requirements: High School-pass, must be available for Day, Evening and Saturday work. Transportation paid, expenses reimbursed.

Which one of the following is the best inference from the above advertisement?

- (A) Gender-discriminatory
- (B) Xenophobic
- (C) Not designed to make the post attractive
- (D) Not gender-discriminatory

Q.64 Given the sequence of terms, AD CG FK JP, the next term is

- (A) OV (B) OW (C) PV (D) PW

Q.65 Which of the following assertions are **CORRECT**?

P: Adding 7 to each entry in a list adds 7 to the mean of the list

Q: Adding 7 to each entry in a list adds 7 to the standard deviation of the list

R: Doubling each entry in a list doubles the mean of the list

S: Doubling each entry in a list leaves the standard deviation of the list unchanged

- (A) P, Q (B) Q, R (C) P, R (D) R, S

END OF THE QUESTION PAPER

Space for Rough Work

HowToExam.com

Space for Rough Work

HowToExam.com

Space for Rough Work

HowToExam.com

Space for Rough Work

HowToExam.com

Space for Rough Work

HowToExam.com

Space for Rough Work

HowToExam.com